

Furnaces

Laboratory and Industrial



**Precise, Efficient, and Reliable
Furnaces and Process Systems
Made to Your Specifications**

Table of Contents



Introduction	3
Furnaces	4-19
Series 3110 Tube Furnaces	4-5
Series 3210 Split Tube Furnaces	4-5
Series 3150 Box Furnaces	6-7
Series 3160 Split Box Furnaces	6-7
Series 3310 High-Temperature Tube Furnaces	8-9
Series 3320 High-Temperature Split Tube Furnaces	8-9
Series 3330 Low-Profile High-Temperature Furnaces	10-11
Series 3330S Low-Profile High-Temperature Furnaces	10-11
Series 3350 High-Temperature Box Furnaces	12-13
Series 3350A High-Temperature Box Furnaces	12-13
Series 3410 Silicon Carbide Tube Furnaces	14-15
Series 3420 Silicon Carbide Split Tube Furnaces	14-15
Series 3410B Silicon Carbide Tube Furnaces	16-17
Series 3420B Silicon Carbide Split Tube Furnaces	16-17
Series 3450 Silicon Carbide Box Furnaces	18-19
Furnace Accessories	20-25
Quartz Viewports	20
End Caps, Port Plugs, Temperature Sensors	21
Extensometer Flats, Zone Dividers, Sample Supports	22
Element Shields, Heat Shields, Sealed Terminal Covers	23
Heat Equalizing Blocks, Controlled-Atmosphere Furnaces, Access Ports	24
Sealed Retort Assemblies	25
Furnace Mounting Components	26-27
Support Brackets, Support Plates, Mounting Brackets	26
Laboratory Baseplates, Vertical Support Stands	27
Test Frame Mounting Assemblies	28-29
Structural Frames	28
Vertical Support Columns, UTM Baseplates	29
Custom Equipment	30-34
Custom Furnaces	30-31
High-Temperature Process Systems	32
Mounting Arrangements	33
Industrial Furnaces	34
Temperature Control Systems	35-36

Laboratory and Industrial Furnaces from ATS

Since 1965, Applied Test Systems, Inc. (ATS) has been working to create an unmatched line of precise and affordable materials testing equipment. A large part of this effort has been in the field of high-temperature testing and production. As a result of nearly four decades of research, development, design, testing, and re-testing, ATS has created a complete line of furnaces and high-temperature accessory items that is unmatched in quality, versatility, and reliability.

The standard line of ATS furnaces has been designed for general laboratory use and also for testing to ASTM standards and other specifications. All ATS furnaces are constructed to customer requirements in a wide variety of diameters, lengths, sizes, and configurations, and are shipped complete with mounting brackets and accessory equipment. Heating elements are provided in various materials and configurations depending upon temperature requirements and the specific application. Furnaces have been designed for easy replacement of failed elements in the laboratory, saving you time and money.

Outstanding design features such as the use of low K-factor vacuum-cast ceramic fiber insulation and low watt-density heating elements provides significant advantages and benefits to the user, including reduced power consumption, faster heatup, longer element life, and lower shell temperatures.

Several different types of furnaces are available, including tube, split tube, box, split box, high-temperature, low-profile, silicon carbide, controlled-atmosphere, and industrial furnaces. All are described separately in this bulletin along with furnace accessories, mounting arrangements, components, and retorts. This bulletin also demonstrates the custom design capabilities for which ATS has become known worldwide. With over 30 years of design experience in custom testing equipment, ATS is sure to provide you with an ideal solution for all of your high-temperature testing and manufacturing needs.

In addition to furnace systems, ATS manufactures a complete line of laboratory testing machines and accessories, including universal testing machines, creep/stress-rupture test frames, convection ovens/cryogenic cooling chambers, pressure testing systems, asphalt testing equipment, and sealant testers, as well as grips, fixtures, load train components, extensometers, ultrasonic reference standards, and more. Come to ATS for all of your materials testing concerns, and you can rest assured that the equipment delivered to your facility will precisely meet all of your needs and expectations.

Features

Series 3110/3210

Based on the original series of ATS furnaces, our Series 3110 Tube and 3210 Split Tube Furnaces are by far our most popular line. These furnaces have been carefully designed and refined over many years to make them one of the most reliable and efficient laboratory furnaces available on the market today.

Standard construction features include low K-factor vacuum-cast ceramic fiber insulation for superior energy retention and rigid structure, stainless steel shell and end flanges for both durability and appearance, and laboratory-replaceable heating elements manufactured under strict quality-controlled conditions in our own factory.

All Series 3110/3210 furnaces are built-to-order to your specific requirements, with a wide selection of available diameters, lengths, mounting arrangements, and accessory equipment, in a variety of configurations, including isothermal, gradient, adiabatic, and others.

Available options and accessories include heat-equalizing liners, extensometer slots and mounting flats, thermocouples, end caps, viewports, gas ports, cast bronze or brass heating elements, retorts, and more.

SERIES 3110

Tube Furnace
2200°F (1200°C) Maximum

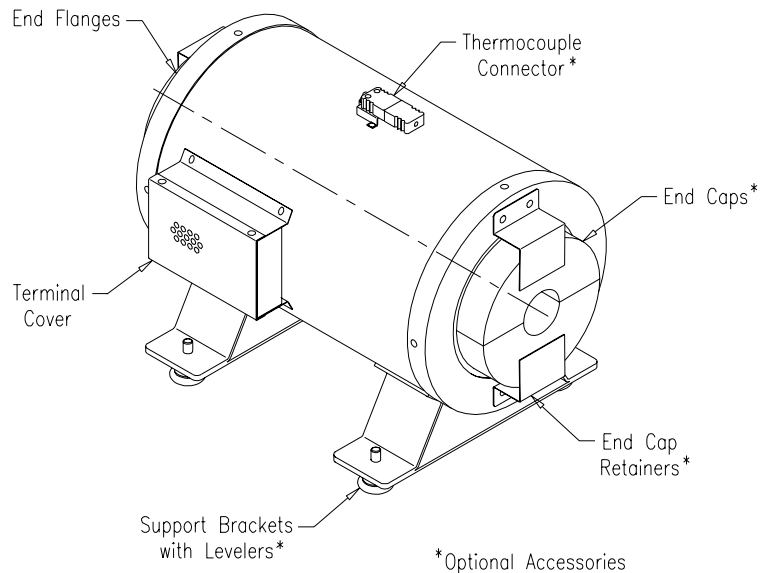

SERIES 3210

Split Tube Furnace
2200°F (1200°C) Maximum

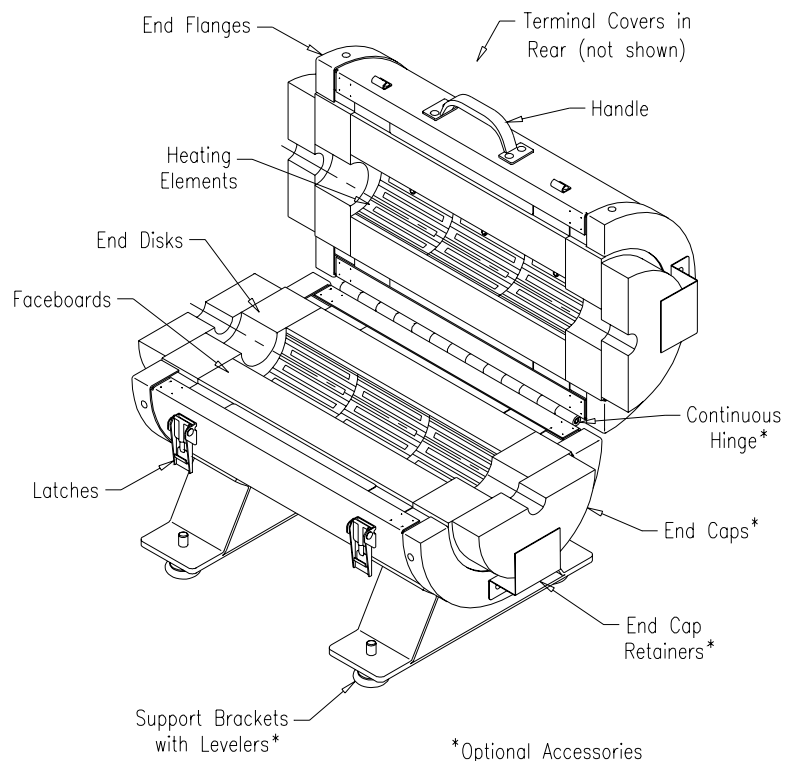

Specifications

Series 3110/3210:

- Other sizes supplied on request
- Length & zone construction made to order
- Heating elements and temperature range:
 Nichrome: 1850°F (1000°C)
 Kanthal A1: 2200°F (1200°C)
- UL Listed (in standard configurations, selected sizes only, with approved control system)

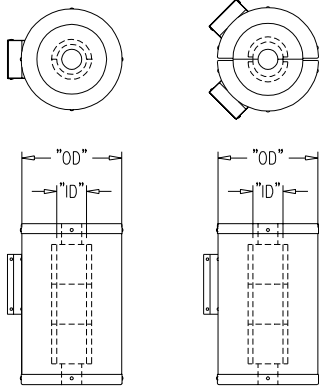

Series 3110

Series 3210

Typical Furnace Sizes		
For service to 1650°F (900°C)	For service to 2000°F (1100°C)	For service to 2200°F (1200°C)
"ID" x "OD"	"ID" x "OD"	"ID" x "OD"
0.75" x 6.0"	0.75" x 8.0"	0.75" x 10.0"
1.00" x 6.0"	1.00" x 8.0"	1.00" x 10.0"
1.25" x 6.0"	1.25" x 8.0"	1.25" x 10.0"
1.62" x 8.0"	1.62" x 10.0"	1.62" x 12.0"
2.00" x 8.0"	2.00" x 10.0"	2.00" x 12.0"
2.38" x 8.0"	2.38" x 10.0"	2.38" x 12.0"
3.00" x 8.0"	3.00" x 10.0"	3.00" x 12.0"
3.75" x 10.0"	3.75" x 12.0"	3.75" x 14.0"
5.00" x 10.0"	5.00" x 12.0"	5.00" x 14.0"
5.50" x 12.0"	5.50" x 14.0"	5.50" x 16.0"
6.00" x 12.0"	6.00" x 14.0"	6.00" x 16.0"
7.00" x 12.0"	7.00" x 14.0"	7.00" x 16.0"
8.25" x 16.0"	8.25" x 18.0"	8.25" x 20.0"
12.0" x 20.0"	12.0" x 22.0"	12.0" x 24.0"



Creep Testing Furnaces

For the ultimate in precise temperature control and uniformity, ATS furnaces can be combined with our exclusive WinCCS II computer creep system. This industry-leading hardware/software package automates every aspect of the creep testing process, including control, data acquisition, archiving, analysis, report generation, and much more. (See Bulletin 2020 for more information.)

Typical Heatup Curve

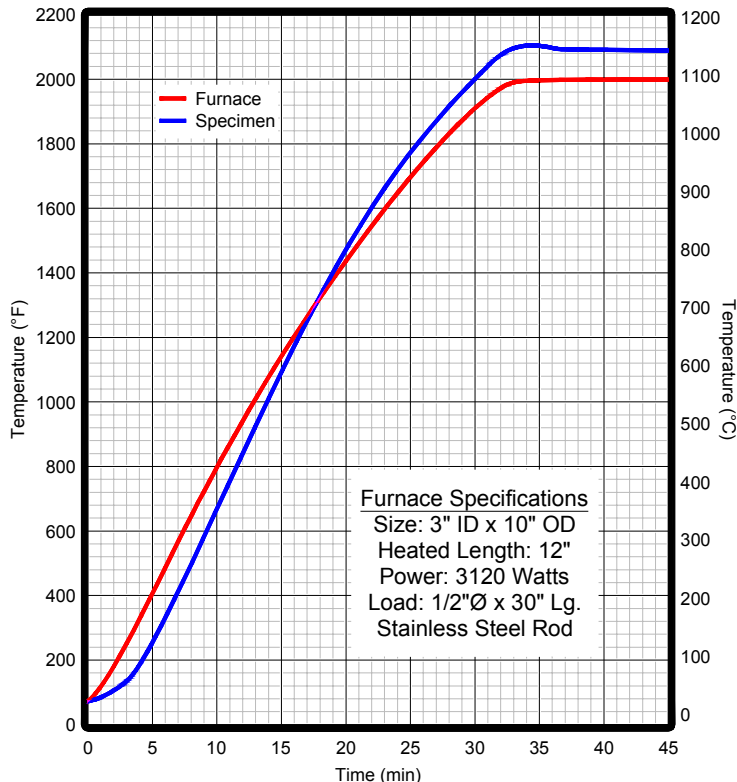

Uniformity Curves

(Isothermal and Gradient Furnaces)

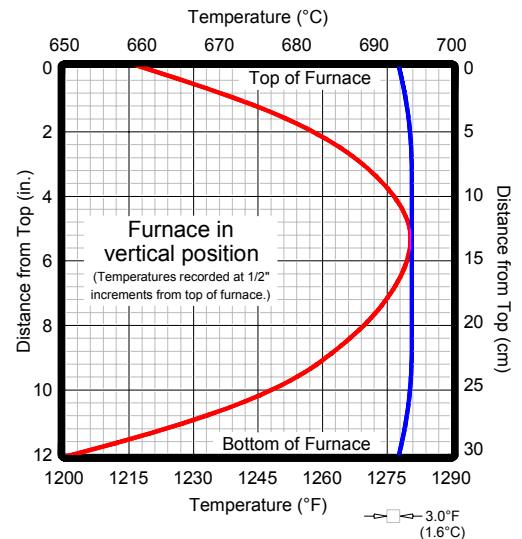

Restrictions apply. See above.

— Gradient curve: Large gradient achieved with three-zone furnace and appropriate control system.

— Isothermal curve: Three-zone furnace in a creep testing setup under WinCCS II digital control.

Features

Series 3150/3160

For basic laboratory and testing applications, ATS Series 3150 Box and 3160 Split Box Furnaces are an ideal choice. Used in testing installations around the world, these furnaces are unmatched in quality construction and affordable prices.

As the box-style counterparts to our Series 3110/3210 tube and split tube models, these furnaces share a number of the same advanced design and construction features, including low K-factor vacuum-cast ceramic fiber insulation for superior energy retention, a rugged stainless steel shell for both durability and appearance, and laboratory-replaceable heating elements manufactured under strict quality-controlled conditions in our own factory. Additionally, Series 3150 laboratory box furnaces feature a full-opening door with double-pivot hinge for unrestricted access to the heating chamber.

ATS Series 3150/3160 furnaces are available in a number of standard sizes, or they can be built-to-order to your specifications. A variety of options and accessories can be utilized to suit all of your testing needs, including load train ports, thermocouples, viewports, gas ports, offset or removable hinges, custom heating elements, muffles, liners, and more.

SERIES 3150

Box Furnace
2200°F (1200°C) Maximum

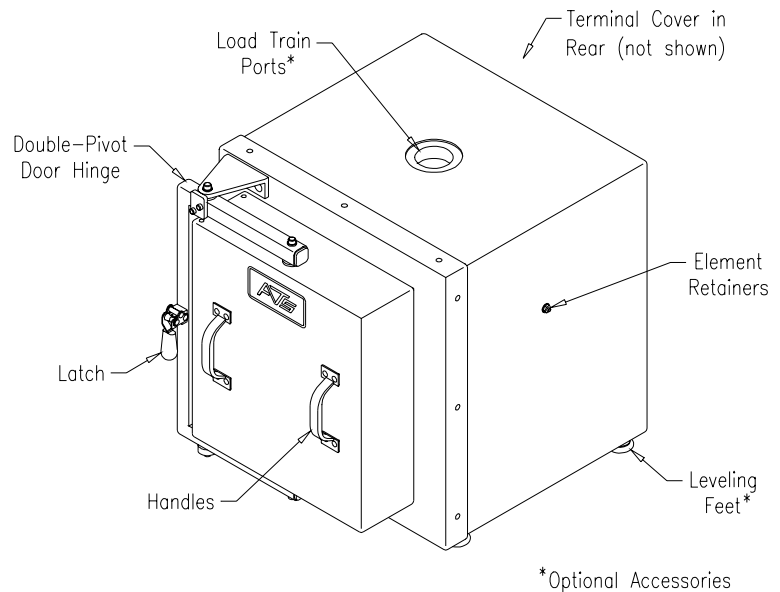

SERIES 3160

Split Box Furnace
2200°F (1200°C) Maximum

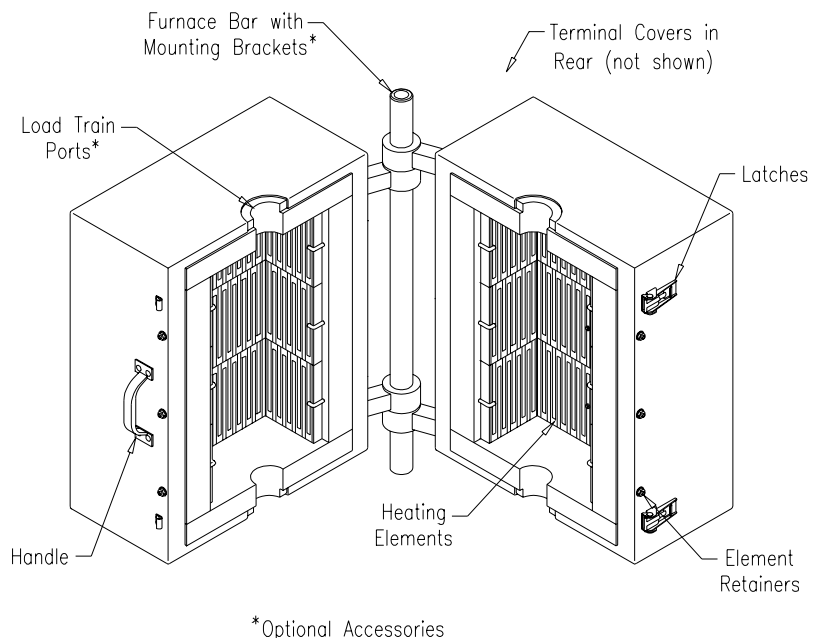

Specifications

Series 3150/3160:

- Other sizes and zone arrangements supplied on request
- Heating elements and temperature range:
 Nichrome: 1850°F (1000°C)
 Kanthal A1: 2200°F (1200°C)

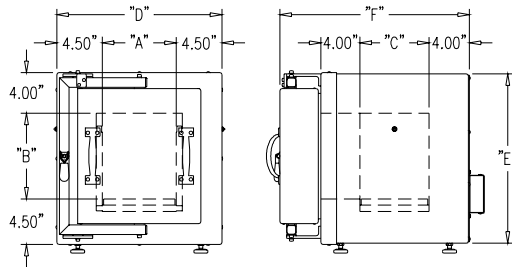
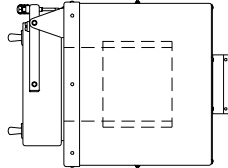

Fig. 1: Series 3150

Notes:

1. Depth of rear terminal cover varies from 1.50" to 2.75" depending on furnace power.
2. Leveling feet are included when no other mounting arrangement is specified.

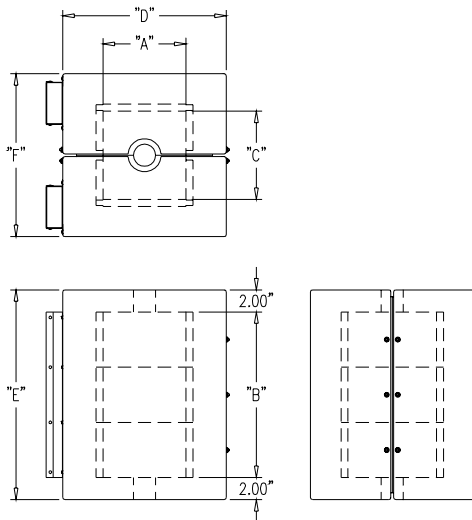

Fig. 2: Series 3160

Notes:

1. Size of terminal covers varies considerably depending on power and zone arrangement.

Standard Models: Series 3150 Box Furnaces (Refer to Fig. 1)										
Nominal Size (WxHxD)	"A"	"B"	"C"	"D"	"E"	"F"	Power (Watts)		Volts	
							Nichrome	Kanthal A1		
5.5" x 6.5" x 6"	5.50"	6.50"	6.00"	14.5"	15.0"	18.25"	1290	1770	115	
5.5" x 6.5" x 12"	5.50"	6.50"	12.0"	14.5"	15.0"	21.25"	2070	2460	230	
7.5" x 8.75" x 7"	7.50"	8.75"	7.00"	16.5"	17.25"	19.25"	1515	2040	115	
7.5" x 8.75" x 14"	7.50"	8.75"	14.0"	16.5"	17.25"	26.25"	3030	4080	230	
10" x 10" x 12"	10.0"	10.0"	12.0"	19.0"	18.5"	24.25"	3750	5100	230	
10" x 10" x 16"	10.0"	10.0"	16.0"	19.0"	18.5"	28.25"	4200	5700	230	
12" x 13.5" x 12"	12.0"	13.5"	12.0"	21.0"	22.0"	24.25"	4500	6000	230	
12" x 13.5" x 18"	12.0"	13.5"	18.0"	21.0"	22.0"	30.25"	6750	9000	230	

Standard Models: Series 3160 Split Box Furnaces (Refer to Fig. 2)										
Nominal Size (WxDxH)	Heat Zones	"A"	"B"	"C"	"D"	"E"	"F"	Power (Watts)		Volts
								Nichrome	Kanthal A1	
6" x 6" x 6"	1	6.00"	6.00"	6.50"	12.5"	10.0"	12.5"	1720	2360	115 ^{1/2} / ₂₃₀
6" x 6" x 12"	3	6.00"	12.0"	6.50"	12.5"	16.0"	12.5"	3440	4680	115 ^{1/2} / ₂₃₀
7.5" x 7.5" x 7"	1	7.50"	7.00"	8.00"	14.75"	11.0"	14.75"	2020	2720	115 ^{1/2} / ₂₃₀
7.5" x 7.5" x 15"	3	7.50"	15.0"	8.00"	14.75"	19.0"	14.75"	4330	5830	115 ^{1/2} / ₂₃₀
10" x 10" x 12"	1	10.0"	12.0"	10.5"	17.5"	16.0"	17.5"	5000	6600	230
10" x 10" x 18"	3	10.0"	18.0"	10.5"	17.5"	22.0"	17.5"	7500	9900	230
12" x 12" x 12"	1	12.0"	12.0"	12.5"	19.5"	16.0"	19.5"	6000	8000	230
12" x 12" x 24"	3	12.0"	24.0"	12.5"	19.5"	28.0"	19.5"	12000	16000	230

Typical Heatup Curve

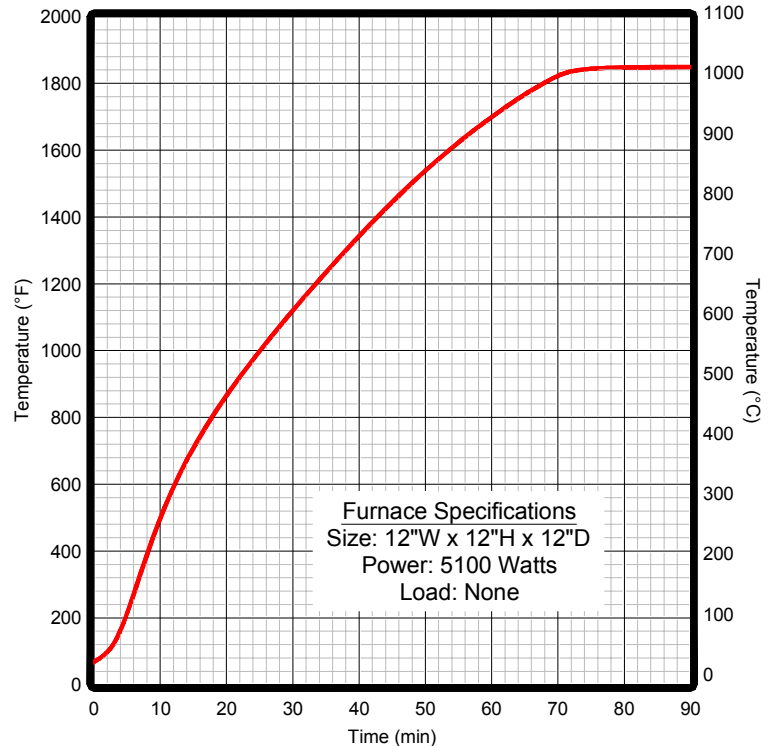

Features

Series 3310/3320

ATS Series 3310 High-Temperature Tube and 3320 High-Temperature Split Tube Furnaces offer a reliable solution for requirements that demand temperatures up to 3272°F (1800°C). These furnaces are also an ideal choice for lower-temperature applications where time is critical, due to the rapid heat-up and cool-down rates made possible by superior components and years of refinement in design.

All ATS high-temperature furnaces utilize Kanthal Super[®] molybdenum disilicide (MoSi₂) heating elements for improved resistance to oxidation, longer element life, easier replacement of failed elements, faster heat-up, and greater resistance to thermal shock. Additional construction features include low K-factor vacuum-cast ceramic fiber insulation for superior energy retention and rigid structure, as well as a stainless steel shell and end flanges for both durability and appearance.

A wide selection of standard sizes, mounting arrangements, and accessory equipment is available, and custom design inquiries are always welcome. Available options and accessories include extensometer slots and mounting flats, end caps and port plugs, thermocouples, viewports, ceramic retorts, and more.

SERIES 3310
High-Temperature Tube Furnace
3272°F (1800°C) Maximum

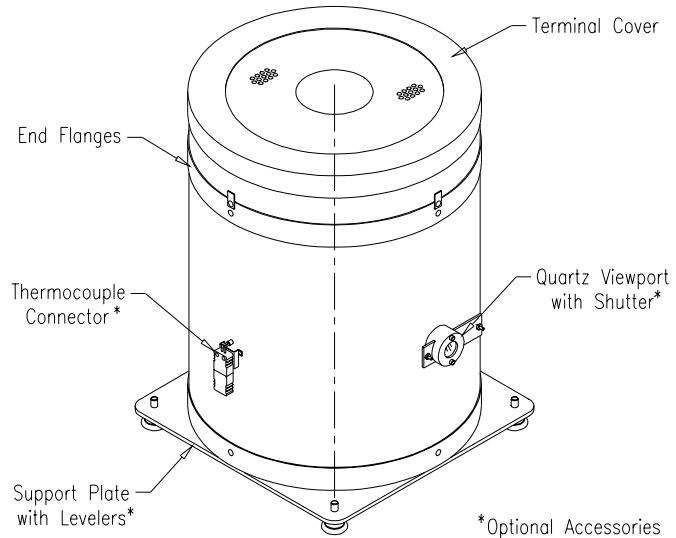

SERIES 3320
High-Temperature Split Tube Furnace
3272°F (1800°C) Maximum

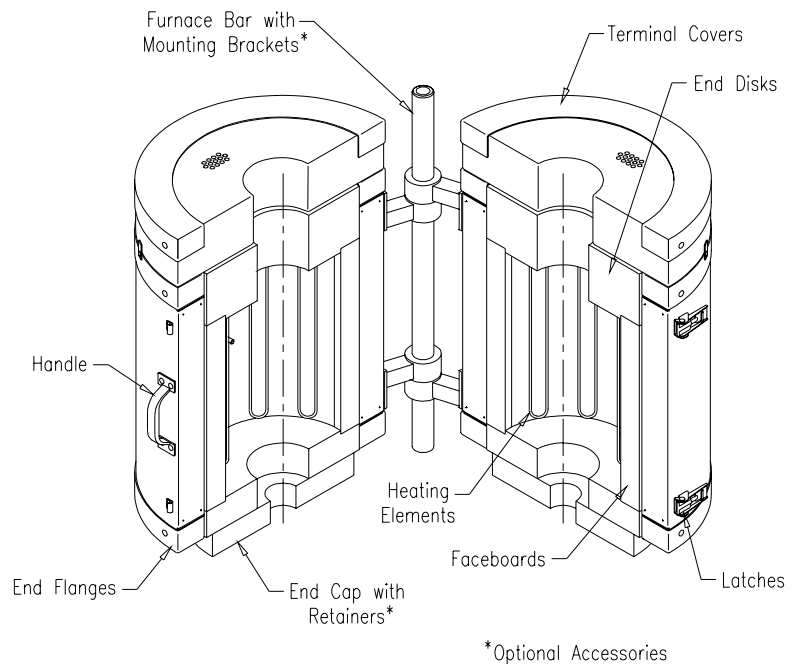

Specifications

Series 3310/3320:

- Other sizes and multiple-heat-zone furnaces supplied on request
- Furnaces must be oriented vertically; see page 12 for horizontal high-temperature tube furnace options
- Heating elements:
Kanthal Super® (MoSi₂)

Note: These furnaces operate at low voltage and high current, requiring a transformer and current-limiting device in the control system.

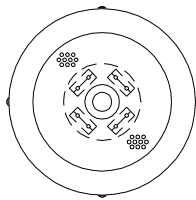

Series 3310

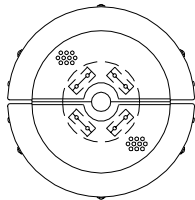

Series 3320

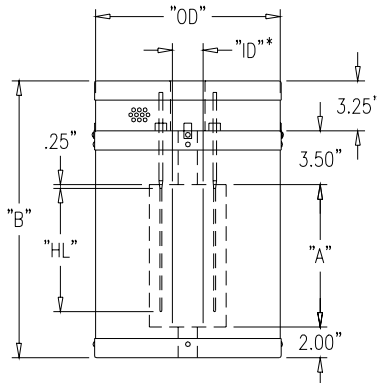

*Maximum working diameter

Exterior Temperatures

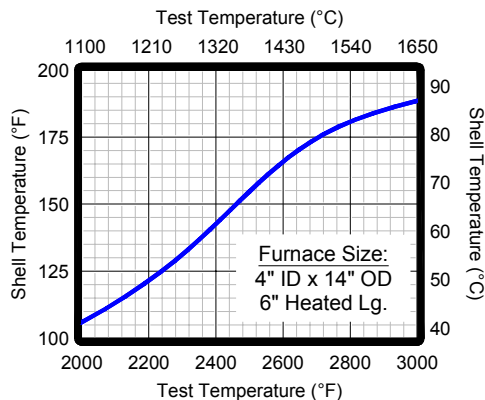

Standard Models: Series 3310/3320 High-Temperature Furnaces											
For Service to 2800°F (1540°C)						For Service to 3100°F (1700°C)					
"ID" x "OD"	"HL"	"A"	"B"	Power (Watts)	Volts	"ID" x "OD"	"HL"	"A"	"B"	Power (Watts)	Volts
2.0" x 12.0"	4.0"	5.25"	14.0"	1080	24.0	2.0" x 14.0"	4.0"	5.25"	14.0"	1620	36.0
	6.0"	7.25"	16.0"	1520	33.6		6.0"	7.25"	16.0"	2280	50.4
	8.0"	9.25"	18.0"	1960	43.6		8.0"	9.25"	18.0"	2940	65.4
	10.0"	11.25"	20.0"	2400	53.2		10.0"	11.25"	20.0"	3600	79.8
	11.0"	12.25"	21.0"	2624	58.0		11.0"	12.25"	21.0"	3936	87.0
4.0" x 14.0"	4.0"	5.25"	14.0"	1620	36.0	4.0" x 16.0"	4.0"	5.25"	14.0"	2160	48.0
	6.0"	7.25"	16.0"	2280	50.4		6.0"	7.25"	16.0"	3040	67.2
	8.0"	9.25"	18.0"	2940	65.4		8.0"	9.25"	18.0"	3920	87.2
	10.0"	11.25"	20.0"	3600	79.8		10.0"	11.25"	20.0"	4800	106.4
	11.0"	12.25"	21.0"	3936	87.0		11.0"	12.25"	21.0"	5248	116.0
6.0" x 18.0"	6.0"	7.25"	16.0"	3800	84.0	6.0" x 20.0"	6.0"	7.25"	16.0"	3800	84.0
	8.0"	9.25"	18.0"	4900	109.0		8.0"	9.25"	18.0"	4900	109.0
	10.0"	11.25"	20.0"	6000	133.0		10.0"	11.25"	20.0"	6000	133.0
	11.0"	12.25"	21.0"	6560	145.0		11.0"	12.25"	21.0"	6560	145.0

ATS high-temperature tube and split tube furnaces for service to 3272°F (1800°C), referred to as "3310A" and "3320A" respectively, are engineered on an individual basis in order to optimize element size and arrangement based upon your specific requirements. Consult an ATS sales engineer for more information.

Typical Heatup Curve

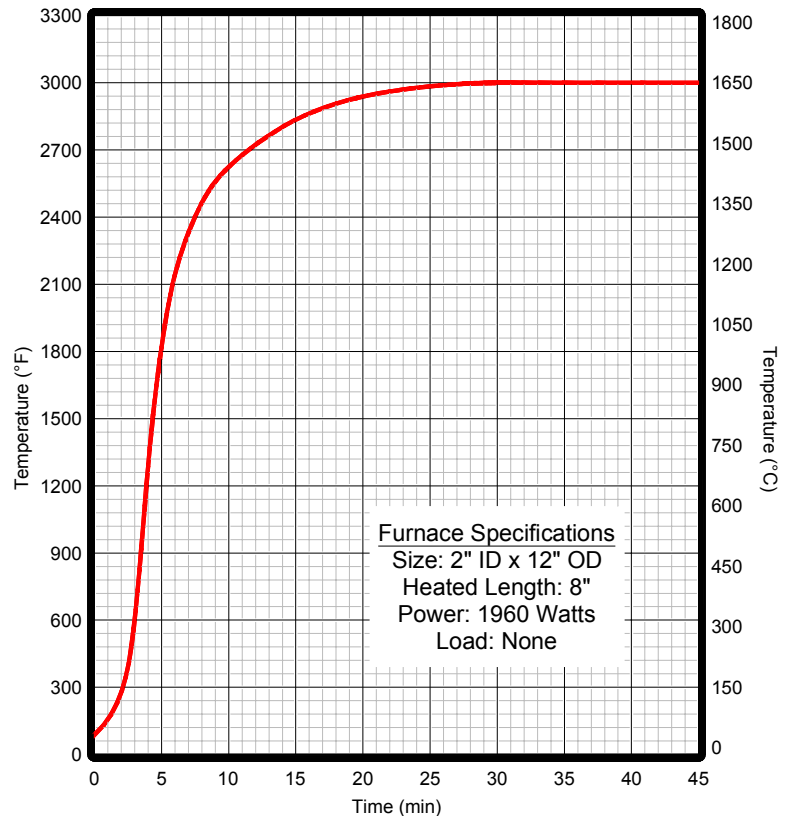

Features

Series 3330/3330S

For applications where available testing space is severely restricted due to specimen size or other factors, ATS Series 3330 and 3330S High-Temperature Furnaces offer an ideal low-profile solution. These furnaces feature highly compact construction while maintaining efficient temperature capabilities up to 3000°F (1650°C). Due to a small internal working volume, rapid heat-up and cool-down rates are attainable for testing of ceramics, metal alloys, composites, and other materials, using either flat or round specimens.

Standard construction features include large-diameter Kanthal Super® molybdenum disilicide (MoSi₂) heating elements that are available from stock and are easily replaceable in the laboratory, low K-factor vacuum-cast ceramic fiber insulation, and stainless steel shells, end flanges, and element covers for durability, safety, and appearance.

In addition to standard furnace sizes, custom sizes and zone arrangements are built-to-order, and a wide variety of mounting arrangements, optional construction features, and accessory equipment is available, including high-temperature extensometers, extensometer slots, thermocouples, viewports, water-cooled specimen grips, testing fixtures, and more.

SERIES 3330

High-Temperature Furnace
3000°F (1650°C) Maximum

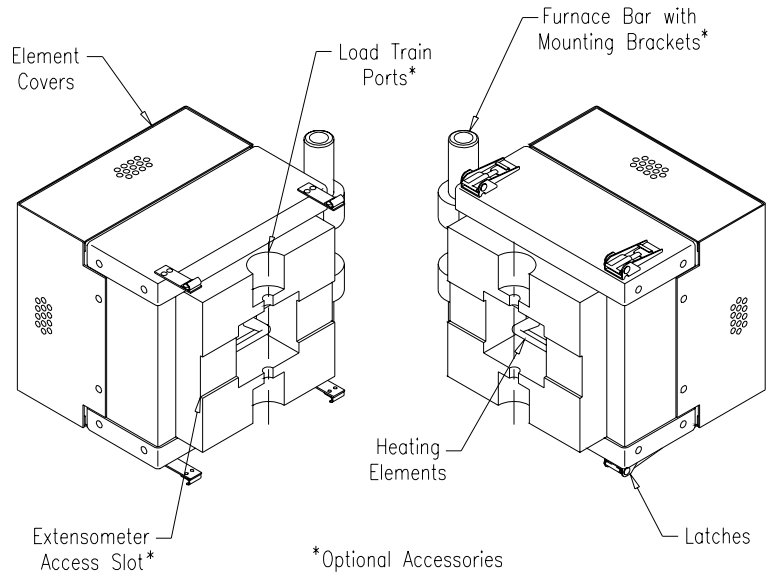

SERIES 3330S

High-Temperature Furnace
2912°F (1600°C) Maximum

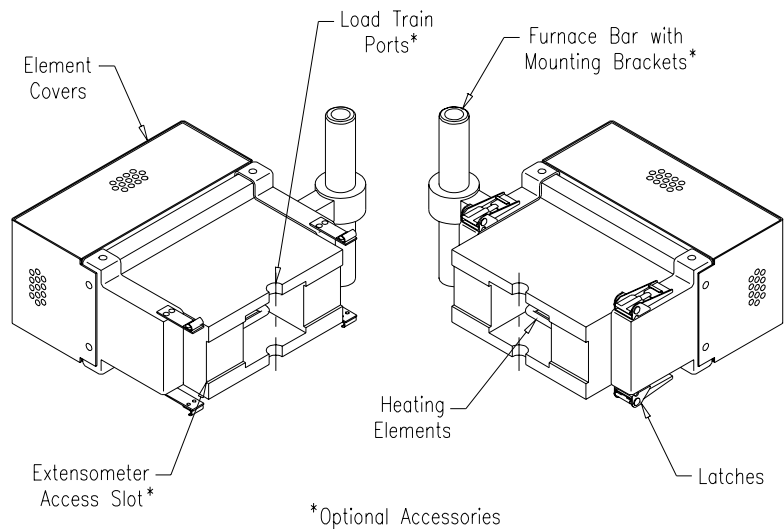

Specifications

Series 3330/3330S:

- Other sizes supplied on request
- Standard furnaces can be configured for one or two heating zones; custom zone arrangements are available
- Heating elements:
Kanthal Super® (MoSi₂)

Note: These furnaces operate at low voltage and high current, requiring a transformer and current-limiting device in the control system.

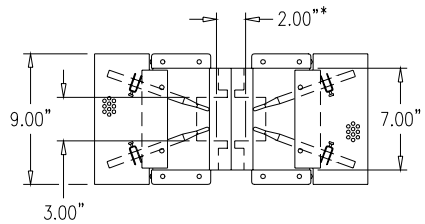
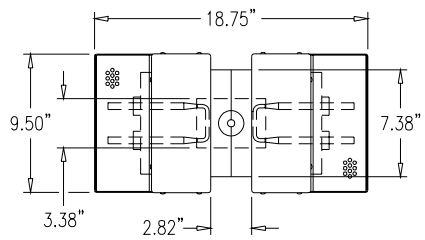

*Maximum working width

Series 3330
Power Requirements:
1040 Watts @ 8.0 Volts

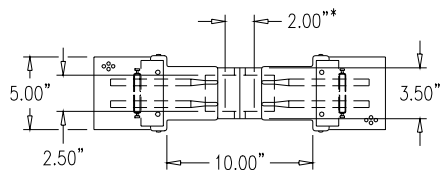
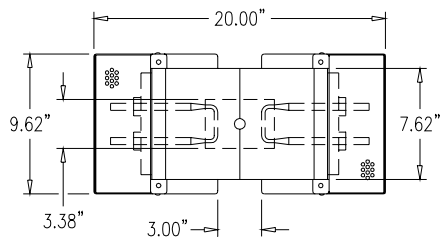

*Maximum working width

Series 3330S
Power Requirements:
1040 Watts @ 8.0 Volts

Typical Testing Setup
Series 3330 Furnace

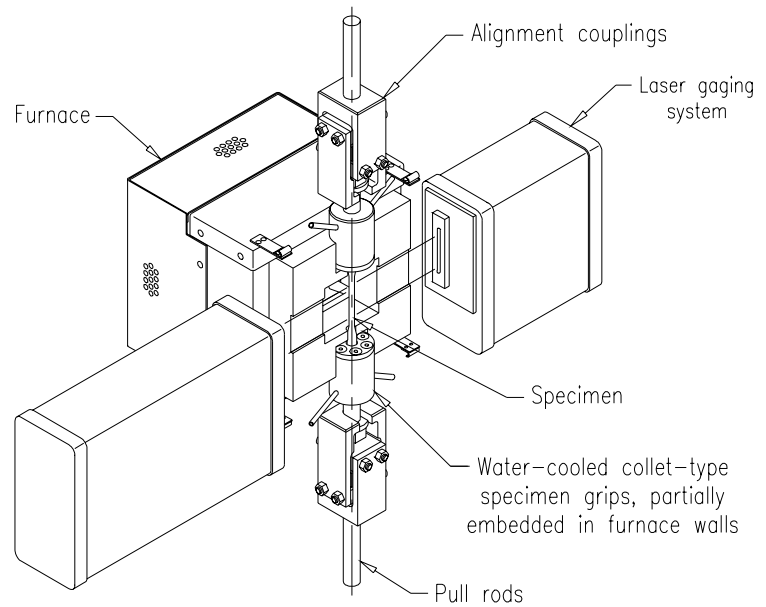

Typical Heatup Curve

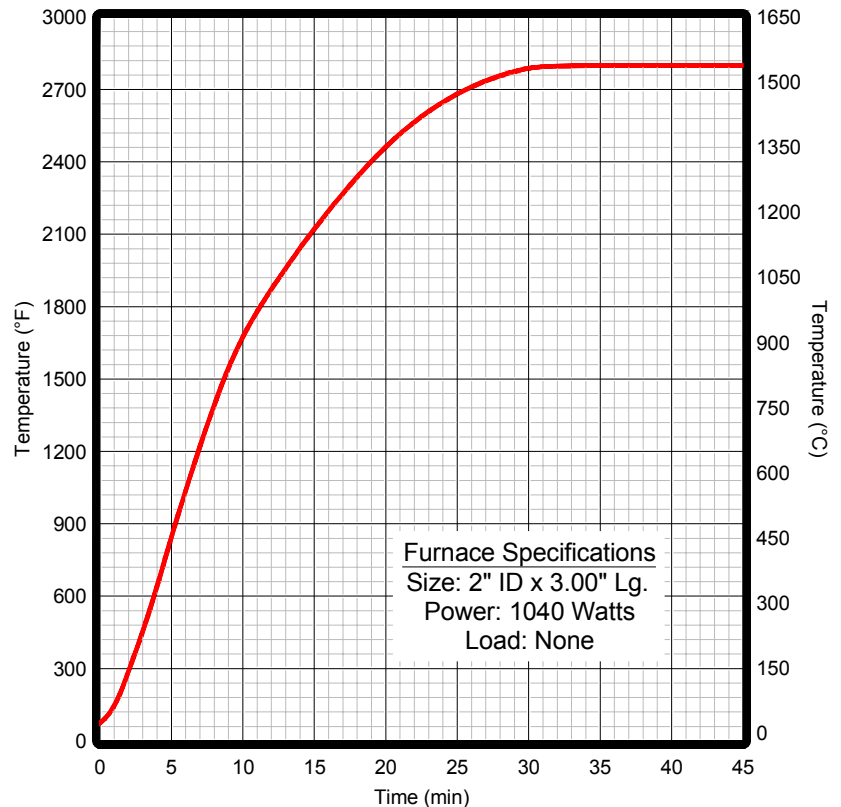

Features

Series 3350/3350A

Series 3350 and 3350A High-temperature Box Furnaces are ATS's line of high-efficiency, rapid heat-up/cool-down laboratory chambers designed for operating temperatures up to 3272°F (1800°C). These furnaces feature superior design and construction, with several layers and grades of insulating materials, enabling them to maintain uniform temperatures with minimal losses.

As with all ATS high-temperature furnaces, these models make use of efficient Kanthal Super® molybdenum disilicide (MoSi_2) heating elements, available from stock and easily replaceable in the laboratory, as well as low K-factor vacuum-cast ceramic fiber insulation for superior energy retention. Additionally, these furnaces feature a rugged stainless steel case, a durable interior, and a full-opening front door for unrestricted access to the heating chamber. Series 3350A furnaces also feature double-shell construction, with an air gap for greatly reduced external surface temperatures.

A wide selection of standard models is available, and custom designs are an ATS specialty. Optional accessory features include load train ports, thermocouples, viewports, laser gaging ports, gas-tight retorts, mounting assemblies, grips, fixtures, and more.

SERIES 3350

High-Temperature Box Furnace
3000°F (1650°C) Maximum

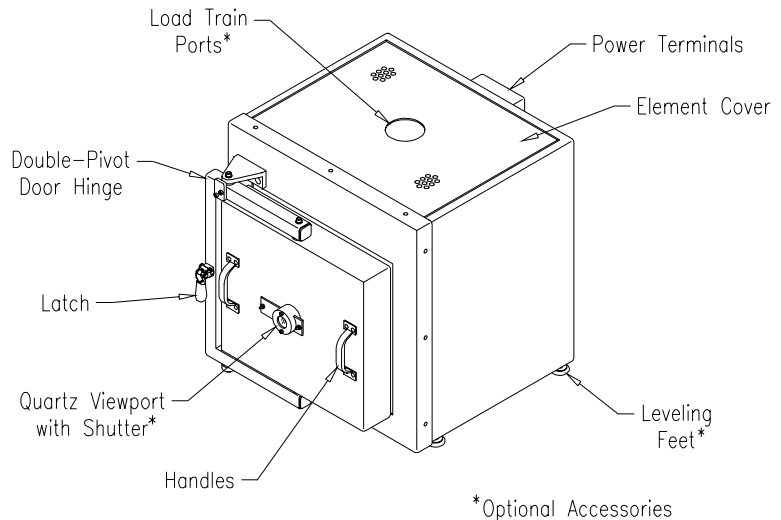

SERIES 3350A

High-Temperature Box Furnace
3272°F (1800°C) Maximum

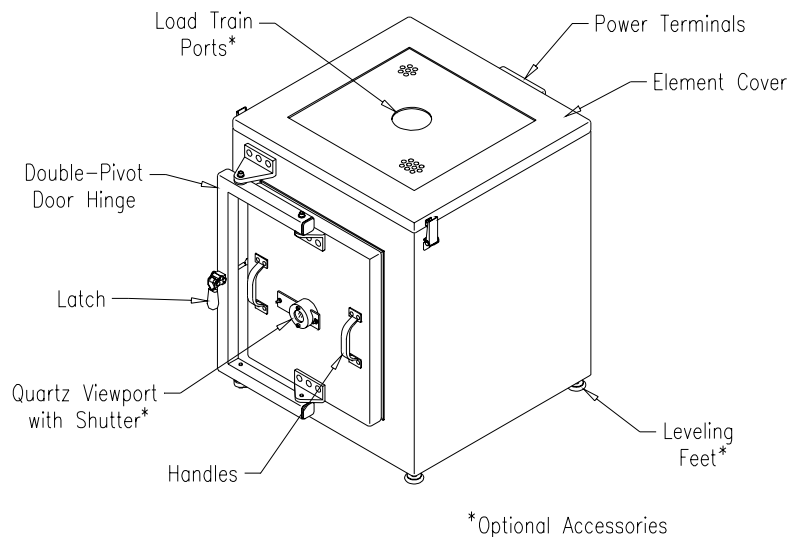

Note: Also available from ATS are Series 3350/3350A Horizontal High-Temperature Tube Furnaces and Series 3360/3360A Horizontal High-Temperature Split Tube Furnaces. These "square tube" models are very similar to the box furnaces described here, except that they are constructed without doors and typically with access ports at each end. Basic sizes, power requirements, and overall dimensions are nearly identical to Series 3350/3350A Box Furnaces as detailed on the following page. See page 31 of this bulletin for an example.

Specifications

Series 3350/3350A:

- Other sizes and multiple-heat-zone furnaces supplied on request
- Available in standard construction (as shown) or horizontal tube/split tube
- Heating elements: Kanthal Super® (MoSi₂)

Note: These furnaces operate at low voltage and high current, requiring a transformer and current-limiting device in the control system.

Nominal Size (WxHxD)	"A"	"B"	"C"	"D"	"E"	"F" (based on service temp.)		Power (Watts)	Volts
						2800°F / 1540°C	3000°F / 1650°C		
4.0" x 4.0" x 6.0"	4.00"	4.00"	6.50"	16.0"	16.50"	16.0"	17.0"	1620	36
4.0" x 4.0" x 12.0"	4.00"	4.00"	12.50"	16.0"	16.50"	22.0"	23.0"	3240	72
6.0" x 6.0" x 7.0"	6.00"	6.00"	8.50"	18.0"	18.50"	18.0"	19.0"	3040	67
6.0" x 6.0" x 14.0"	6.00"	6.00"	14.50"	18.0"	18.50"	24.0"	25.0"	5320	118
8.0" x 8.0" x 9.0"	8.00"	8.00"	10.50"	20.0"	20.50"	20.0"	21.0"	4900	108
8.0" x 8.0" x 18.0"	8.00"	8.00"	18.50"	20.0"	20.50"	28.0"	29.0"	8820	196
10.0" x 10.0" x 11.0"	10.0"	10.0"	12.50"	22.0"	22.50"	22.0"	23.0"	7200	160
10.0" x 10.0" x 22.0"	10.0"	10.0"	22.50"	22.0"	22.50"	32.0"	33.0"	13200	147*
12.0" x 12.0" x 13.0"	12.0"	12.0"	14.50"	24.0"	24.50"	24.0"	25.0"	9184	204
12.0" x 12.0" x 26.0"	12.0"	12.0"	26.50"	24.0"	24.50"	36.0"	37.0"	15744	174*

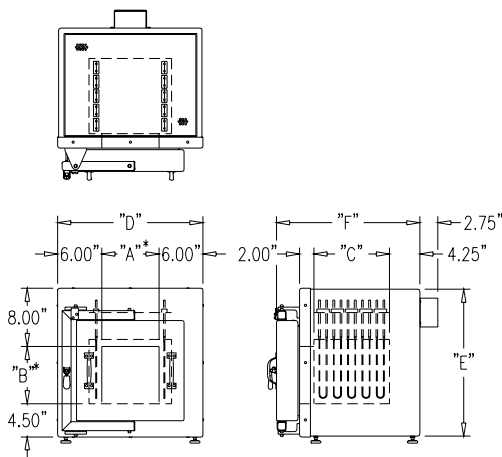

Fig. 1: Series 3350

Service Temp.	Nominal Size (WxHxD)	"A"	"B"	"C"	"D"	"E"	"F"	Power (Watts)	Volts
3100°F / 1700°C	4.0" x 4.0" x 6.0"	4.00"	5.00"	6.50"	15.50"	19.50"	16.50"	1620	36
	4.0" x 4.0" x 12.0"	4.00"	5.00"	12.50"	15.50"	19.50"	22.50"	3240	72
	6.0" x 6.0" x 7.0"	6.00"	7.00"	8.50"	17.50"	21.50"	18.50"	3040	67
	6.0" x 6.0" x 14.0"	6.00"	7.00"	14.50"	17.50"	21.50"	24.50"	5320	118
	8.0" x 8.0" x 9.0"	8.00"	9.00"	10.50"	19.50"	23.50"	20.50"	4900	108
	8.0" x 8.0" x 18.0"	8.00"	9.00"	18.50"	19.50"	23.50"	28.50"	8820	196
	10.0" x 10.0" x 11.0"	10.0"	11.0"	12.50"	21.50"	25.50"	22.50"	7200	160
	10.0" x 10.0" x 22.0"	10.0"	11.0"	22.50"	21.50"	25.50"	32.50"	13200	147*
	12.0" x 12.0" x 13.0"	12.0"	12.0"	14.50"	23.50"	26.50"	24.50"	9184	204
12.0" x 12.0" x 26.0"	12.0"	12.0"	26.50"	23.50"	26.50"	36.50"	15744	174*	
3272°F / 1800°C	4.0" x 4.0" x 6.0"	4.00"	5.00"	6.50"	16.0"	19.25"	17.25"	2000	20
	6.0" x 6.0" x 8.0"	6.00"	7.00"	9.50"	18.0"	21.25"	20.25"	4000	35
	8.0" x 8.0" x 12.0"	8.00"	8.00"	12.50"	20.0"	22.25"	23.25"	6000	55
	10.0" x 10.0" x 14.0"	10.0"	11.0"	15.50"	22.0"	25.25"	26.25"	9000	82

*Volts per circuit (two circuits per furnace)

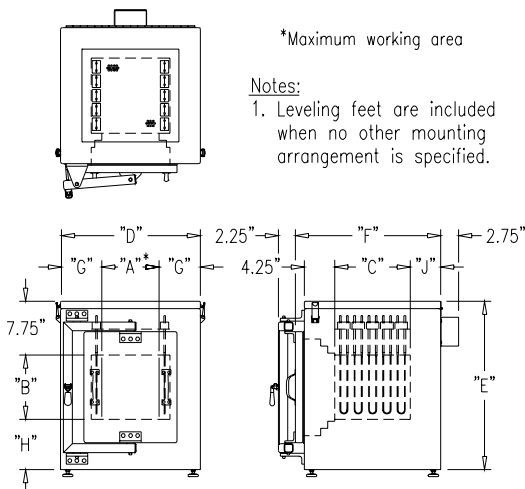
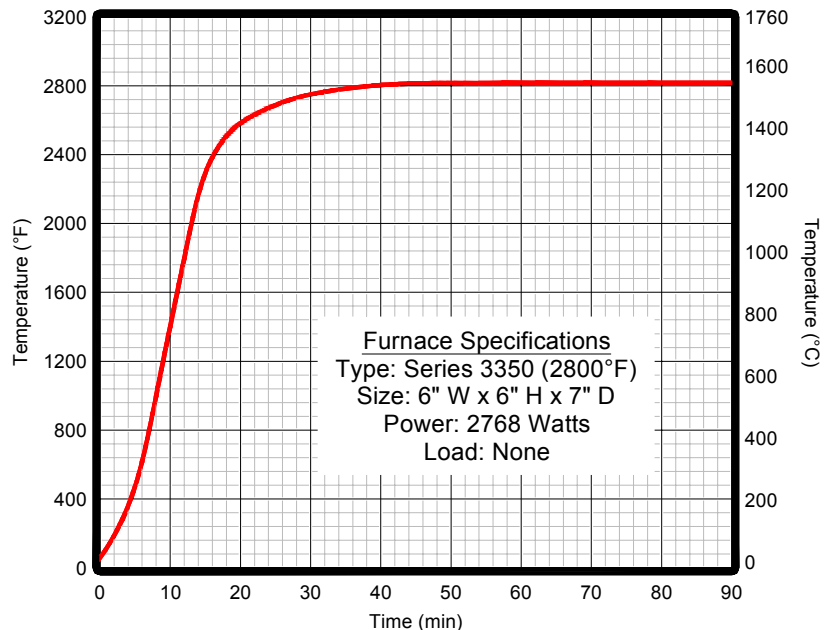

Fig. 2: Series 3350A

Service Temp.	"G"	"H"	"J"
3100°F / 1700°C	5.75"	6.75"	4.25"
3272°F / 1800°C	6.00"	6.50"	5.00"

Typical Heatup Curve



Features

Series 3410/3420

ATS Series 3410 and 3420 Silicon Carbide Tube and Split Tube Furnaces are a line of steady heat-up, high-efficiency furnaces for operating temperatures up to 2800°F (1540°C). As opposed to the rapid heat-up rates offered by the ATS Series 3300 high-temperature models, these furnaces have been designed for a more slow and steady heatup curve, useful for operations involving many types of materials.

The design of these furnaces incorporates silicon carbide (SiC) "rammed rod" type heating elements, which are superior, long-lasting elements owing to their slow aging characteristics, high density, increased strength, and ease of replacement. Similar to other ATS furnaces, additional construction features include low K-factor vacuum-cast ceramic fiber insulation for rigid structure and superior energy retention and a durable stainless steel shell and end flanges.

In addition to the standard models shown on the following page, a wide variety of custom sizes, accessories, and optional features can be incorporated, including load train ports, thermocouples, viewports, gas-tight retorts, ceramic muffle tubes, mounting accessories, temperature control systems, and more.

SERIES 3410
Silicon Carbide Tube Furnace
2800°F (1540°C) Maximum

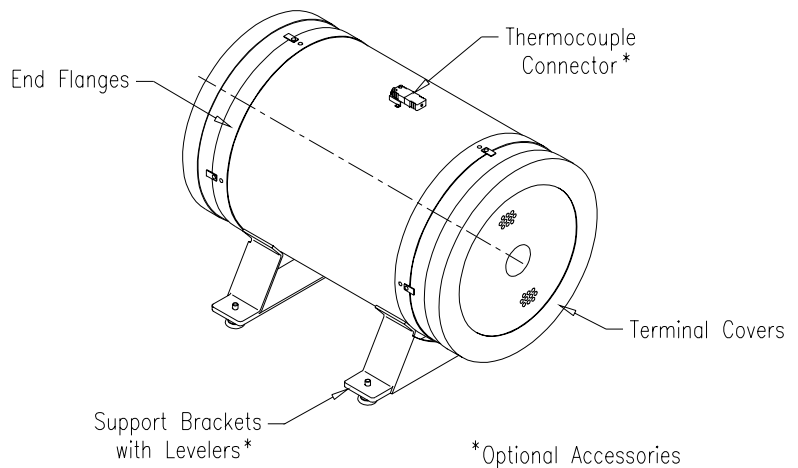

SERIES 3420
Silicon Carbide Split Tube Furnace
2800°F (1540°C) Maximum

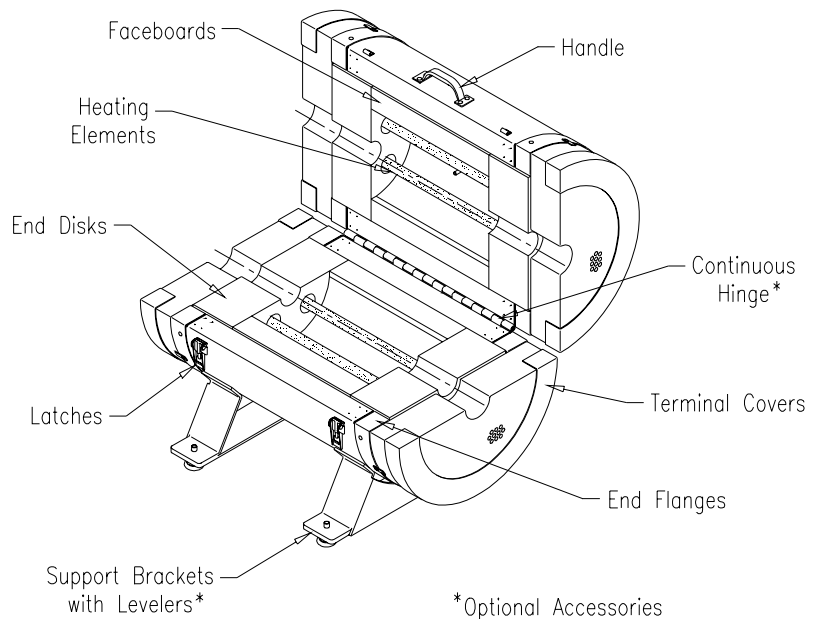

Specifications

Series 3410/3420

- Other sizes and multiple-heat-zone furnaces supplied on request
- Available in standard construction (as shown) or square tube/split tube
- Heating elements: Silicon carbide (SiC) "rammed rod"

Note: These furnaces operate at low voltage and high current, requiring a transformer and current-limiting device in the control system.

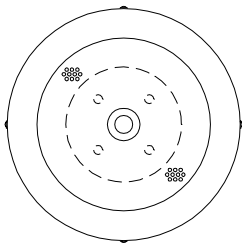

Series 3410

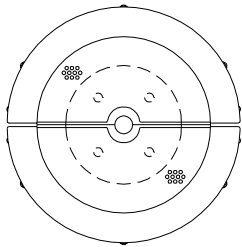

Series 3420

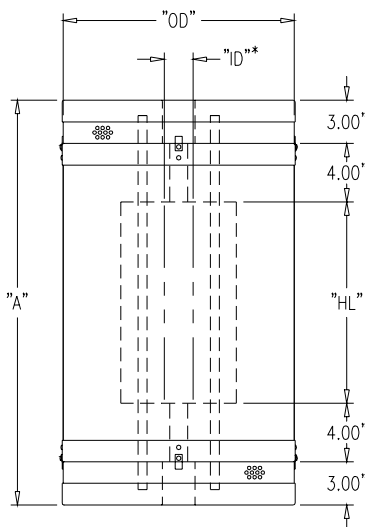

*Maximum working diameter

Standard Models: Series 3410/3420 Silicon Carbide Furnaces									
"ID" x "OD"	"HL"	"A"	Power (Watts)	Volts	"ID" x "OD"	"HL"	"A"	Power (Watts)	Volts
2.0" x 16.0"	5.00"	19.0"	1200	95.0	4.0" x 18.0"	5.00"	19.0"	2300	120.0
	6.00"	20.0"	1350	110.0		6.00"	20.0"	2750	117.0
	7.00"	21.0"	1500	106.0		7.00"	21.0"	3000	130.0
	8.00"	22.0"	1700	106.0		8.00"	22.0"	3300	98.0
	9.00"	23.0"	1800	115.0		9.00"	23.0"	3600	109.0
	10.00"	24.0"	2100	104.0		10.00"	24.0"	3900	118.0
	12.00"	26.0"	2250	118.0		12.00"	26.0"	4500	102.0
	14.00"	28.0"	2800	118.0		12.00"	26.0"	4500	102.0
	18.00"	32.0"	3600	106.0		14.00"	28.0"	5400	102.0
	24.00"	38.0"	5200	97.0		18.00"	32.0"	5750	117.0
	30.00"	44.0"	6420	100.0		20.00"	34.0"	6400	100.0
	36.00"	50.0"	7200	116.0		24.00"	38.0"	7800	100.0
3.0" x 18.0"	5.00"	19.0"	1800	106.0	6.0" x 20.0"	9.00"	23.0"	6750	106.0
	6.00"	20.0"	2100	102.0		12.00"	26.0"	7200	108.0
	7.00"	21.0"	2300	115.0		18.00"	32.0"	8000	110.0
	8.00"	22.0"	2550	104.0		24.00"	38.0"	9200	108.0
	9.00"	23.0"	2800	115.0		30.00"	44.0"	10500	103.0
	10.00"	24.0"	3050	105.0		36.00"	50.0"	12000	100.0
	12.00"	26.0"	3200	118.0					
	14.00"	28.0"	3450	100.0					
	18.00"	32.0"	4200	126.0					
	24.00"	38.0"	6000	104.0					
	30.00"	44.0"	7000	105.0					
	36.00"	50.0"	8200	123.0					

Typical Heatup Curve

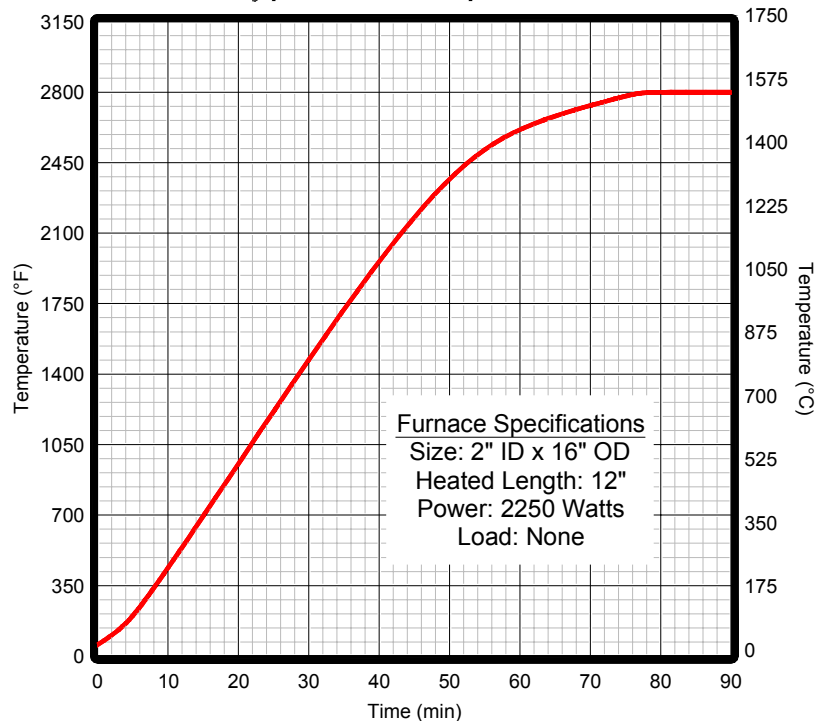

Features

Series 3410B/3420B

For limited-space vertical testing applications where double-ended silicon carbide element furnaces simply occupy too much testing area, ATS Series 3410B and 3420B Silicon Carbide Tube and Split Tube Furnaces are an ideal alternative. Featuring spiral-cut “bayonet” type silicon carbide (SiC) heating elements, these furnaces require power terminals at only one end, reducing the overall length by several inches, while still offering performance and design characteristics similar to those of our standard Series 3410 and 3420 furnaces.

In addition to the previously mentioned benefits of silicon carbide heating elements, including their long life, slow aging characteristics, high density, increased strength, and ease of replacement, these furnaces also incorporate low K-factor vacuum-cast ceramic fiber insulation for rigid structure and superior energy retention, as well as durable stainless steel shells and end flanges.

A wide selection of standard sizes, accessories, and optional features can be integrated, including load train ports, end caps and plugs, thermocouples, quartz viewports, gas-tight retorts, ceramic muffle tubes, mounting accessories, temperature control systems, and more.

SERIES 3410B

Silicon Carbide Tube Furnace
2800°F (1540°C) Maximum

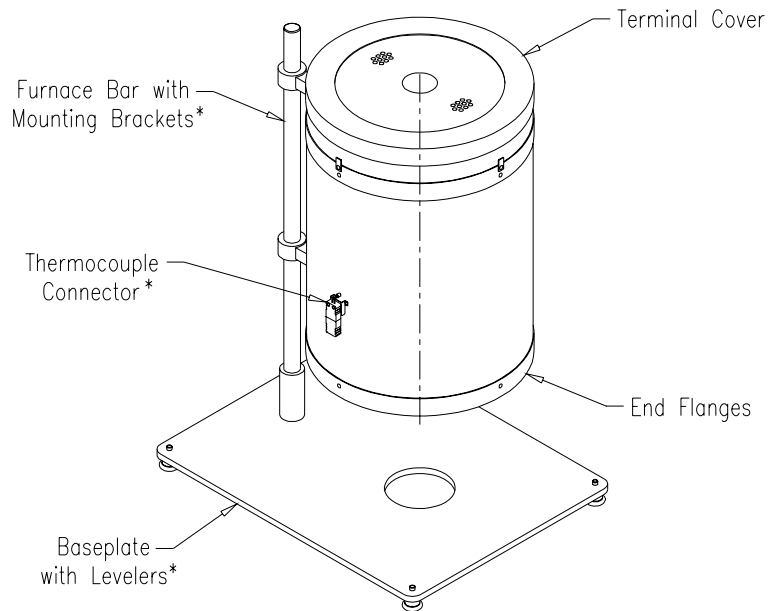

*Optional Accessories

SERIES 3420B

Silicon Carbide Split Tube Furnace
2800°F (1540°C) Maximum

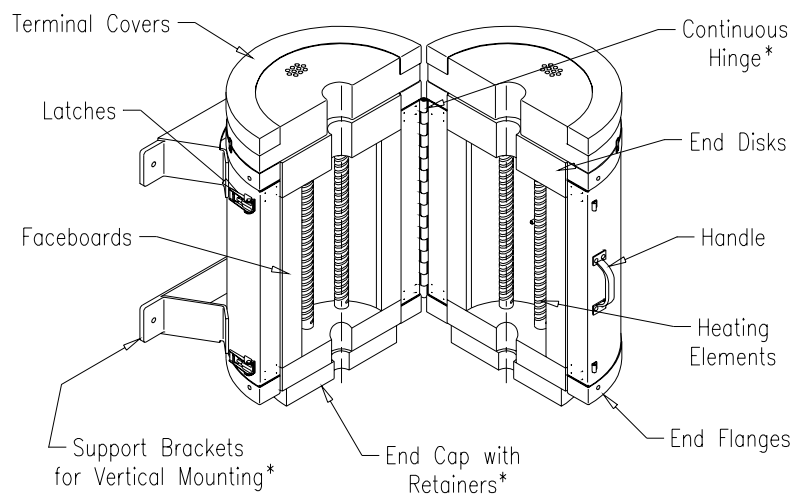

*Optional Accessories

Specifications

Series 3410B/3420B

- Other sizes and multiple-heat-zone furnaces supplied on request
- Available in standard construction (as shown) or square tube/split tube
- Heating elements: Silicon carbide (SiC) "bayonet"

Note: These furnaces operate at low voltage and high current, requiring a transformer and current-limiting device in the control system.

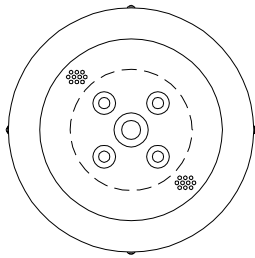

Series 3410B

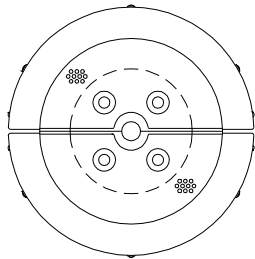

Series 3420B

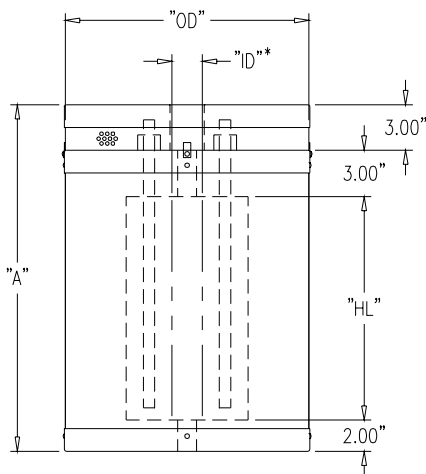

*Maximum working diameter

Standard Models: Series 3410B/3420B Silicon Carbide Furnaces													
"ID" x "OD"	"HL"	"A"	Power (Watts)	Volts	"ID" x "OD"	"HL"	"A"	Power (Watts)	Volts				
2.0" x 16.0"	4.50"	12.50"	1150	116.0	3.0" x 18.0"	10.75"	18.75"	3050	106.0				
	6.50"	14.50"	1350	86.0		12.75"	20.75"	3200	118.0				
	8.50"	16.50"	1700	110.0	4.0" x 18.0"	6.50"	14.50"	2750	120.0				
	9.75"	17.75"	1800	103.0		8.50"	16.50"	3300	98.0				
	10.75"	18.75"	2100	115.0		9.75"	17.75"	3600	108.0				
	12.75"	20.75"	2250	98.0		10.75"	18.75"	3900	117.0				
3.0" x 18.0"	4.50"	12.50"	1700	92.0	12.75"	20.75"	4500	113.0	6.0" x 20.0"	9.75"	17.75"	6750	223.0
	6.50"	14.50"	2100	106.0	12.75"	20.75"	7200	216.0					
	8.50"	16.50"	2500	116.0	6.0" x 20.0"	14.75"	22.75"	7600	228.0				
	9.75"	17.75"	2800	112.0									

Typical Heatup Curve

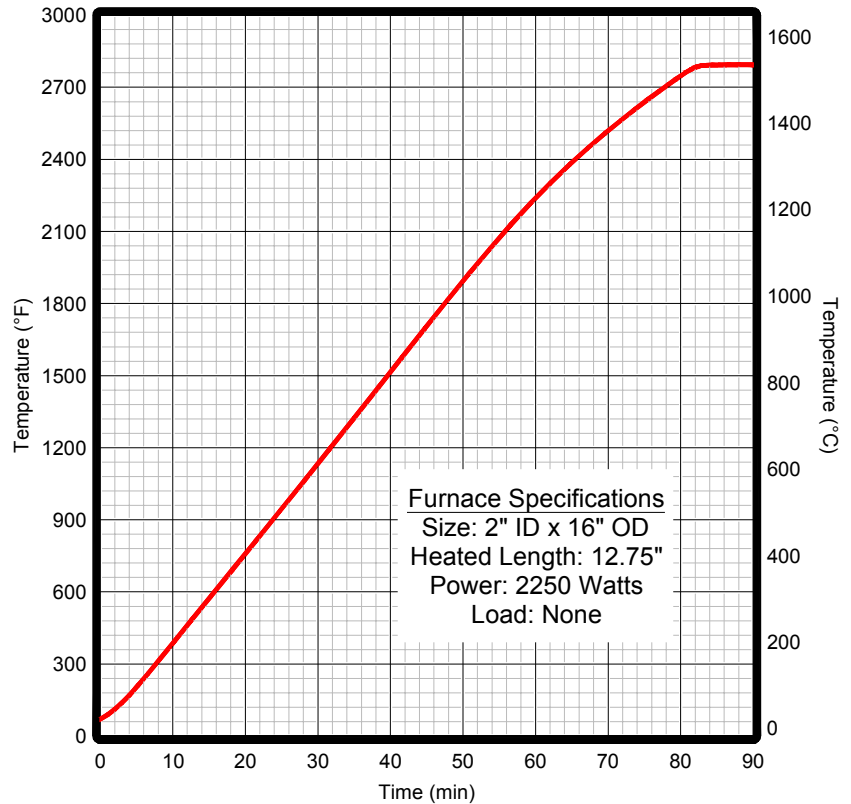

Custom Extended-Length Tube Furnaces:

Also available from ATS are custom multi-zone silicon carbide tube furnaces. These furnaces are designed with a square configuration, similar to that of a box furnace, and are suitable for either horizontal or vertical operation. Common applications include continuous-feed heat treating operations and, more recently, carbon nanotube production and experimentation. Each furnace is individually designed according to your specific application. Consult an ATS sales engineer for more information. (See page 31 of this bulletin for examples.)

Features

Series 3450

If your high-temperature application would benefit from the characteristics and capabilities of silicon carbide heating elements in a laboratory box-style configuration, then ATS Series 3450 Silicon Carbide Box Furnaces are the way to go. Capable of operating temperatures of 2800°F (1540°C), these furnaces have been designed for slow and steady heatup rates with minimal temperature losses.

Series 3450 furnaces incorporate a number of the same superior design features as other ATS furnaces, including low K-factor vacuum-cast ceramic fiber insulation, a rugged and attractive stainless steel case, and a full-opening front door for complete access to the heating chamber. Heating elements are spiral-cut “bayonet” type silicon carbide (SiC), oriented in either a vertical or horizontal configuration.

A number of standard sizes is available, and ATS welcomes all custom inquiries. Additionally, a wide range of available options and accessories allows any ATS furnace to perfectly meet your specific testing needs, including load train ports, thermocouples and connectors, viewports, muffles, liners, gas ports, mounting accessories, temperature control systems, and more.

SERIES 3450

Silicon Carbide Box Furnace
2800°F (1540°C) Maximum

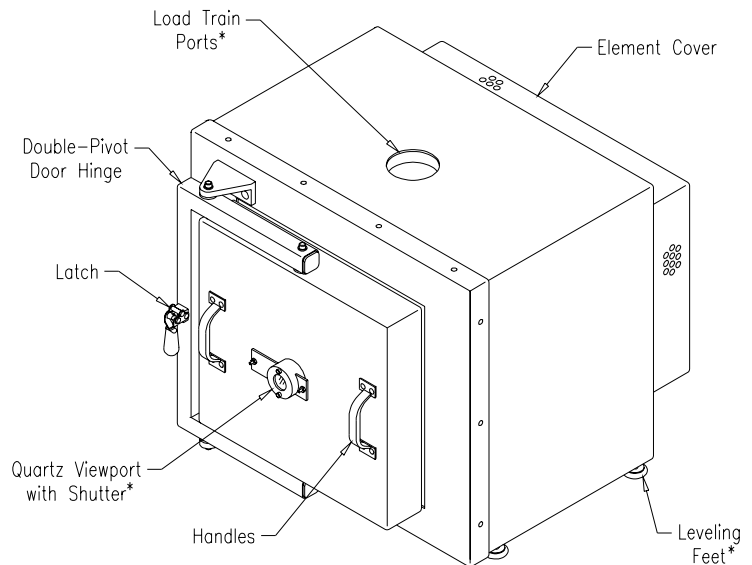

Horizontal Heating Elements

*Optional Accessories

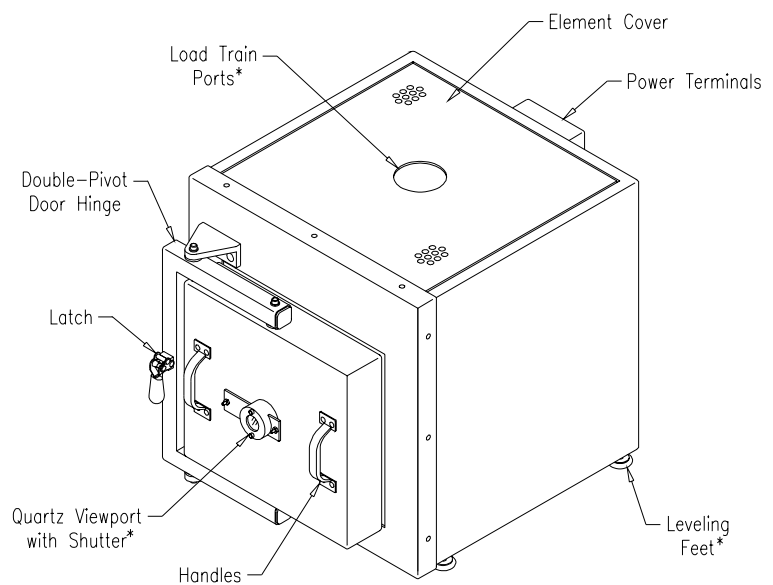

Vertical Heating Elements

*Optional Accessories

Specifications

Series 3450

- Other sizes and multiple-heat-zone furnaces supplied on request
- Available in standard construction (as shown) or square tube/split tube
- Heating elements:
Silicon carbide (SiC) "bayonet"

Note: These furnaces operate at low voltage and high current, requiring a transformer and current-limiting device in the control system.

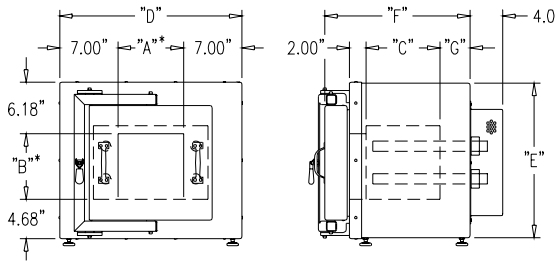
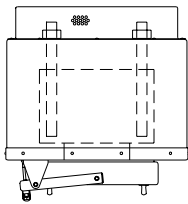
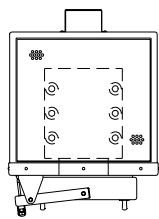

Fig. 1: Series 3450
(with horizontal elements)



*Maximum working area

- Notes:
1. Leveling feet are included when no other mounting arrangement is specified.

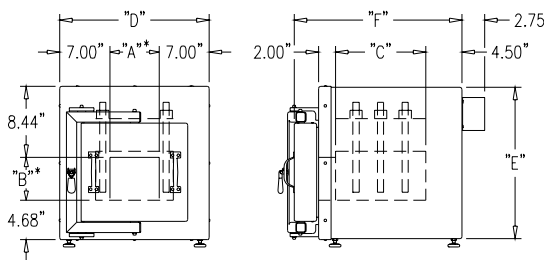
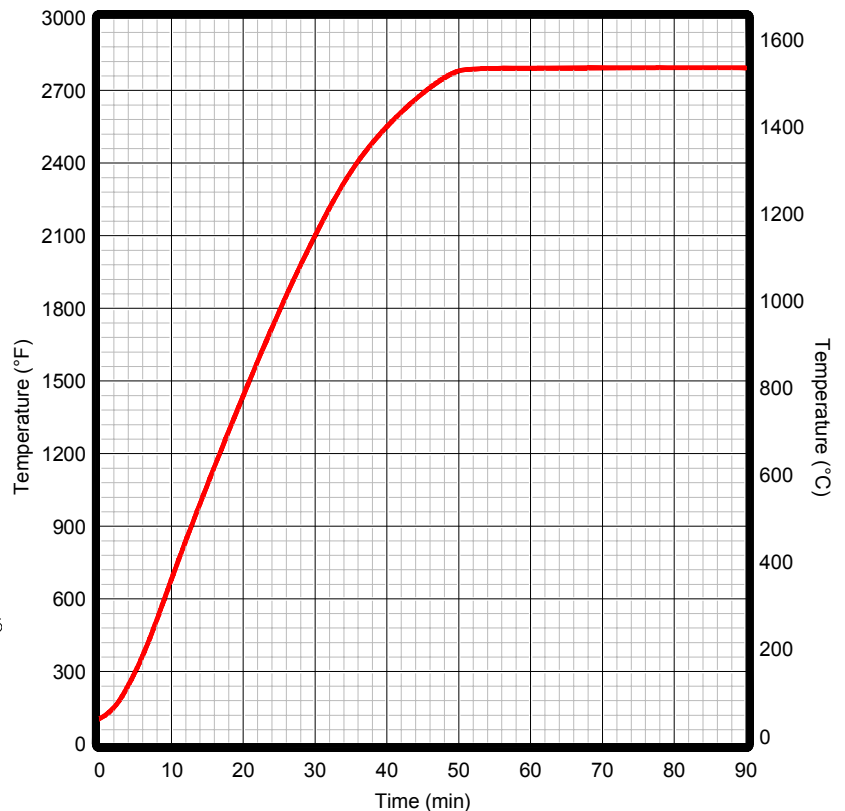

Fig. 2: Series 3450
(with vertical elements)

Standard Models: Series 3450 Silicon Carbide Box Furnaces										
Nominal Size (WxHxD)	Ref. Figure	"A"	"B"	"C"	"D"	"E"	"F"	"G"	Power (Watts)	Volts*
4.0" x 4.0" x 6.0"	1	4.00"	4.00"	7.00"	18.0"	14.88"	15.88"	3.75"	1500	210.0
4.0" x 4.0" x 12.0"	1	4.00"	4.00"	13.0"	18.0"	14.88"	21.88"	3.75"	2100	232.0
6.0" x 6.0" x 7.0"	1	6.00"	6.00"	8.00"	20.0"	16.88"	16.88"	3.75"	2700	230.0
6.0" x 6.0" x 14.0"	2	6.00"	5.38"	14.0"	20.0"	18.50"	23.62"	-	4400	230.0
8.0" x 8.0" x 9.0"	1	8.00"	8.00"	9.00"	22.0"	18.88"	17.88"	3.75"	4200	236.0
8.0" x 8.0" x 18.0"	2	8.00"	7.38"	18.0"	22.0"	20.50"	27.62"	-	6800	230.0
10.0" x 10.0" x 11.0"	2	10.0"	9.38"	11.0"	24.0"	22.50"	20.62"	-	7800	228.0
10.0" x 10.0" x 22.0"	1	10.0"	10.0"	23.0"	24.0"	20.88"	32.38"	4.25"	12400	230.0
10.0" x 10.0" x 22.0"	2	10.0"	9.38"	22.0"	24.0"	22.50"	31.62"	-	11840	230.0
12.0" x 12.0" x 13.0"	1	12.0"	13.0"	13.0"	26.0"	23.88"	22.88"	4.75"	9600	202.0
12.0" x 12.0" x 18.0"	2	12.0"	12.0"	18.0"	26.0"	25.12"	27.62"	-	12000	216.0
12.0" x 12.0" x 26.0"	2	12.0"	12.0"	26.0"	26.0"	25.12"	35.62"	-	16500	230.0

*Operating voltages are based on 240VAC 1Ph. line power.

Typical Heatup Curve



Furnace Specifications
 Size: 6" W x 6" H x 14" D
 Element Orientation: Vertical
 Power: 4400 Watts
 Load: None

Furnace Accessories

ATS offers an unmatched array of quality accessories and optional construction features to complement our extensive line of tube and box furnaces, making possible a truly unlimited number of available configurations. Additionally, because all ATS furnaces are manufactured on a per-order basis, you can rest assured that your new equipment will precisely meet your specific needs and expectations, making time-consuming on-site adjustments and modifications, often needed when working with “off-the-shelf” products, completely unnecessary. Available options and accessories are detailed on the following pages.

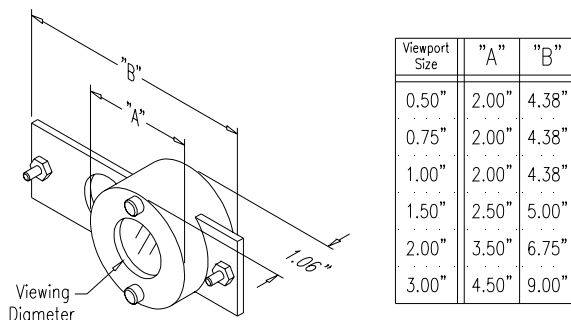

Fig. 1: Circular Viewports

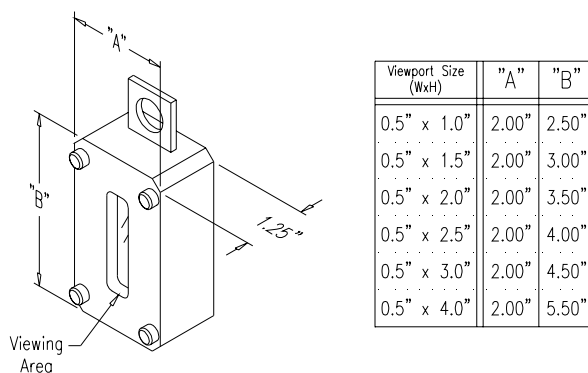

Fig. 2: Rectangular Viewports

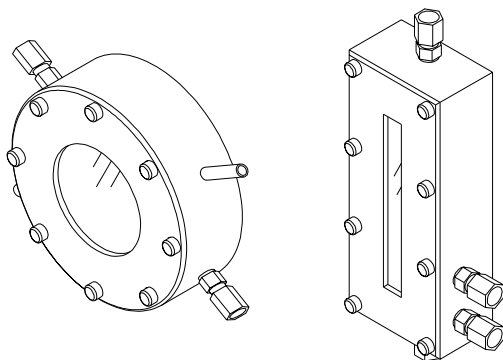

Fig. 3: Sealed Viewports
w/ Water Cooling & Gas Ports

Quartz Viewports

It is often reassuring (and sometimes necessary for a particular test) to be able to visually assess what is happening on the inside of a furnace chamber. In such cases, ATS furnaces can be equipped with quartz viewports, either round or rectangular, to meet this need. Viewports are designed for intermittent viewing and are equipped with a removable insulating shield to reduce heat losses and to prevent possible damage to the quartz material from exposure to heat radiation at higher temperatures (above 1740°F / 950°C).

For applications that make use of laser gaging systems, viewports can be installed using optical-grade quartz to prevent distortion of the beam during testing. Optionally, in cases where condensation is likely to form on the viewport glass, such as in controlled-atmosphere furnaces, viewports can be constructed in a sealed, water-cooled housing with gas ports for defogging of the viewport surface. *Standard sizes shown at left. Custom sizes are available.*

End Caps & Port Plugs

ATS furnaces are commonly supplied with removable and replaceable ends caps or port plugs. These relatively inexpensive accessory items extend furnace life by absorbing “wear and tear” caused by the movement of fixtures, reactors, pull rods, etc., thereby preventing damage to the furnace insulation, which is considerably more expensive and time-consuming to replace.

ATS end caps and port plugs are also useful in situations where a number of different-sized bore diameters are required. They can be easily interchanged, allowing a variety of possible configurations for a single furnace.

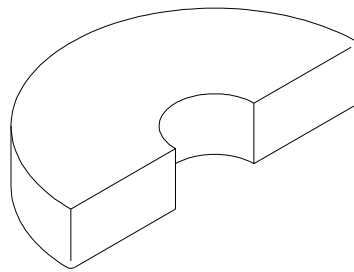

Fig. 1: End Caps

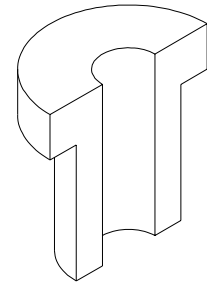

Fig. 2: Port Plugs

Temperature Sensors

Furnaces from ATS can be equipped with a number of different thermocouple types in a variety of mounting configurations. Thermocouple connectors feature standard ANSI color coding and are available in types J, K, B, R, S, and Platinel-II. Common mounting configurations include single connector with mounting bracket, duplex connector with mounting bracket, spring-loaded for constant contact with a reactor or other vessel, and sealed for use in controlled-atmosphere furnaces, retorts, etc.

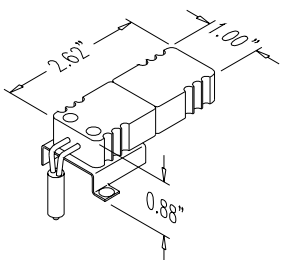

Fig. 3: Single Bracket

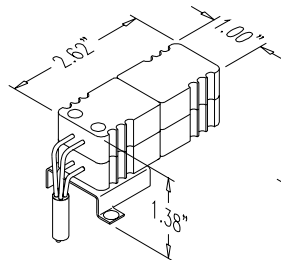

Fig. 4: Duplex Bracket

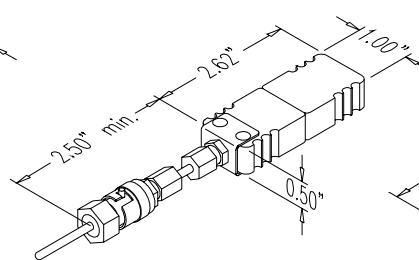

Fig. 5: Spring-Loaded

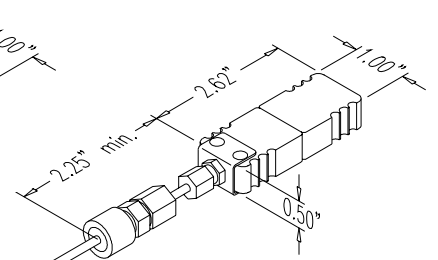

Fig. 6: Sealed

T/C Type	Alloy Combination (+/-)	Max. Temperature	Limits of Error	Comments
ANSI "J"	Fe/Cu-45% Ni	1100°F (590°C)	2.2°C or 0.75%	Reducing, vacuum, inert. Limited use in oxidizing at high temperatures. Not recommended for low temperatures.
ANSI "K"	Ni-10% Cr/ Ni-2% Al-2% Mn-1% Si	2200°F (1200°C)	2.2°C or 0.75%	Clean oxidizing and inert. Limited use in vacuum or reducing. Wide temperature range. Most popular calibration.
ANSI "B"	Pt-30% Rh/Pt-6% Rh	3272°F (1800°C)	0.5% above 800°C	Oxidizing or inert. Do not use in metal tubes. Beware of contamination. High temperature. Common use in glass industry.
ANSI "R"	Pt-13% Rh/Pt	2700°F (1480°C)	1.5°C or 0.25%	Oxidizing or inert. Do not use in metal tubes. Beware of contamination. Precision high temperature.
ANSI "S"	Pt-10% Rh/Pt	2700°F (1480°C)	1.5°C or 0.25%	Oxidizing or inert. Do not use in metal tubes. Beware of contamination. Precision high temperature.
Platinel-II	Platinel-II/Platinel-II	2200°F (1200°C)	1.0%	More stable but more expensive substitute for type "K" thermocouples.

Extensometer Flats & Slots

When performing creep, stress-rupture, and other tests, it is often necessary to have one or more precision extensometers in place to record dimensional changes that occur in a specimen throughout the process. While some extensometers are designed to hang vertically from a specimen to take these measurements, many are intended to contact a specimen from one side, requiring a specially-configured furnace to provide clearance for the extensometer and, in some cases, to also provide support for it.

ATS has extensive experience in designing such furnaces to suit extensometers from nearly every major supplier. *When ordering, please have the information shown in Figure 1 (right) available: a) distance from surface of flat to center of furnace; b) height of flat; c) size (width & height) of access slot; d) sizes & locations (if necessary) of tapped holes for mounting of the extensometer. If available, please also provide the manufacturer and model number of the extensometer being used.*

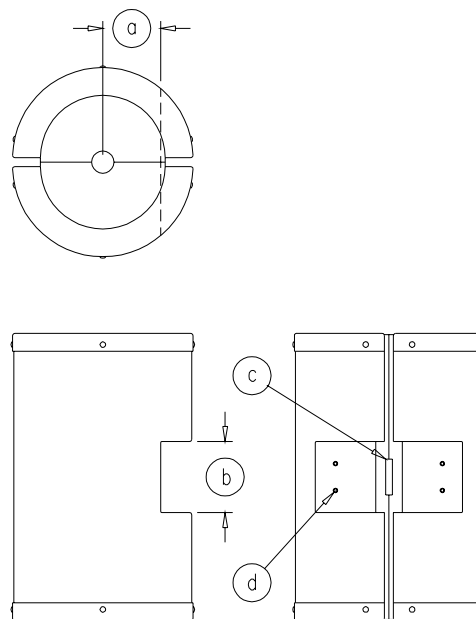

Fig. 1:
Split tube furnace constructed
for extensometer mounting

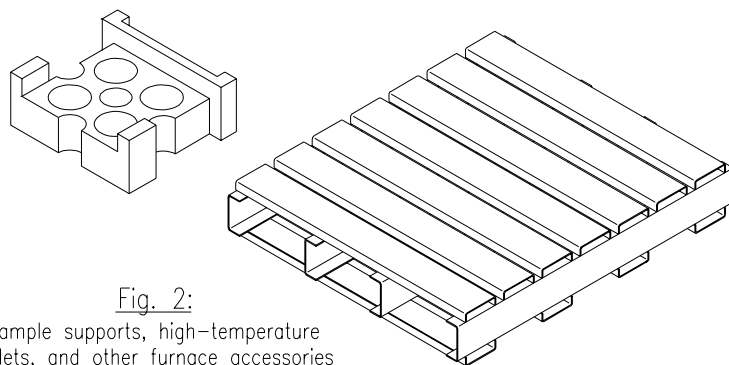

Fig. 2:
Sample supports, high-temperature
pallets, and other furnace accessories
suitable for any configuration.

High-Temperature Sample Supports

For laboratory tests or industrial procedures that do not involve test frames, it is often necessary to have some method of providing support for samples or products that must be heated. ATS meets this need with custom sample supports, specimen holders, and high-temperature pallets made from stainless steel or Inconel for use with fork trucks.

Zone Dividers

Some heating applications involving gasses, liquids, or other substances require a sharp temperature gradient between furnace heating zones. In such cases, ATS furnaces can be constructed with insulating zone dividers to accommodate the required temperature difference.

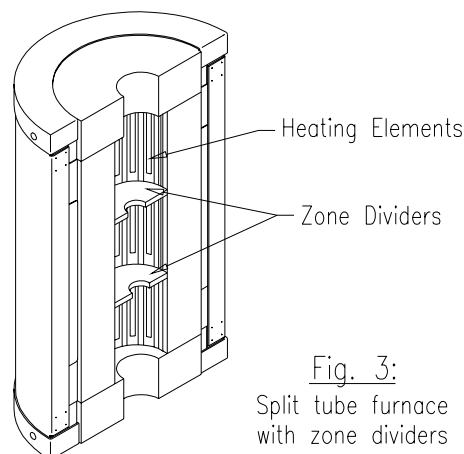

Fig. 3:
Split tube furnace
with zone dividers

Element Protection Shields

Upon breakage, some specimens or samples can create flying debris inside a furnace chamber. Other processes involve reactor vessels with high-pressure liquids or gasses, creating the possibility of pipe rupture. In such cases, internal element protection shields are recommended to prevent damage to furnace heating elements.

ATS tube and split tube furnaces can be supplied with either solid or perforated sheet metal shields, or they can be constructed with embedded ceramic tubes. Box furnaces can be supplied with metal liners or with high-strength refractory sheets installed in front of the heating elements. *Contact ATS to discuss the best option for your application.*

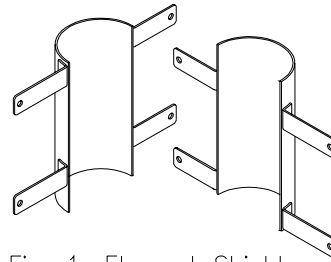

Fig. 1: Element Shields
(for split tube furnaces)

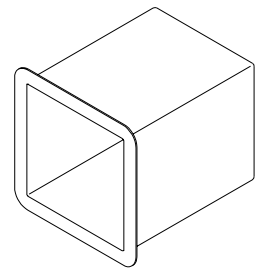

Fig. 2: Protective Liner
(for box furnaces)

Perforated Heat Shields

ATS furnaces are designed for maximum efficiency and low external shell temperatures. However, those who have experience working with high-temperature equipment know that any furnace will be relatively hot on the outside during operation and that appropriate safety precautions must be taken.

While this situation is acceptable in most laboratory environments, many manufacturing facilities that use ATS equipment must meet stringent safety requirements for the protection of their workers. To satisfy this need, ATS furnaces can be supplied with external perforated sheet metal screens, which significantly reduce an operator's exposure to hot surfaces on the furnace shell.

Cast Aluminum

Formed Stainless Steel

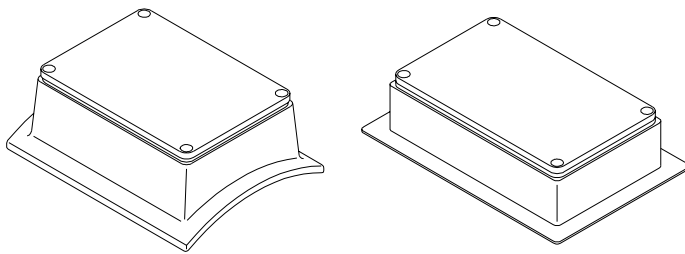

Fig. 3: Sealed Terminal Covers

Sealed Terminal Covers

When heating processes are being conducted in hazardous or corrosive environments, or where required by safety codes, ATS furnaces can be supplied with sealed terminal covers. Sealed covers feature high-temperature silicone rubber gaskets and are supplied in either cast aluminum or formed stainless steel, depending upon the size, type, and power rating of the furnace.

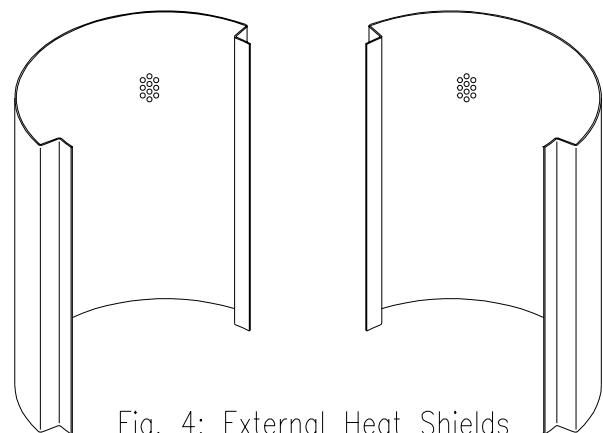

Fig. 4: External Heat Shields
Available for tube or box furnaces,
solid or split, in a variety of configurations.

Heat Equalizing Blocks

Some applications require extreme temperature stability. Achieving this goal requires the addition of a stabilizing thermal mass, or core, to the inside of a heat zone. ATS furnaces can meet this need with the addition of heat equalizing blocks to help ensure that maximum temperature uniformity is maintained, either in a single furnace zone or along the entire length of a furnace.

Though virtually any metal can serve as a core material, the most common alloy used in ATS furnaces is AMPCO-18 cast aluminum-bronze, chosen for its relatively high operating temperature (1100°F/600°C maximum) and its excellent thermal conductivity. Other materials that have been or could be used depending upon the process involved include stainless steel, aluminum, copper, nickel alloys such as Inconel, and others.

Common applications for heat-equalizing blocks include petrochemicals research, pilot plant development, gas and liquid pyrolysis, calibration, viscosity testing, and crystal growth. Custom blocks can be designed for use with any ATS furnace and can include such additional features as thermocouple ports, cooling ports, removable blocks with lifting handles, etc. See page 30 of this bulletin for an example photograph.

• Access Ports

Because all ATS furnaces are built-to-order, nearly any variety or type of access port can be placed wherever necessary to suit your requirements. Types of ports include gas inlets and outlets, purging ports, cooling and vent ports, thermocouple ports and thermowells, load train ports, metal-lined ports, or whatever else your specifications demand.

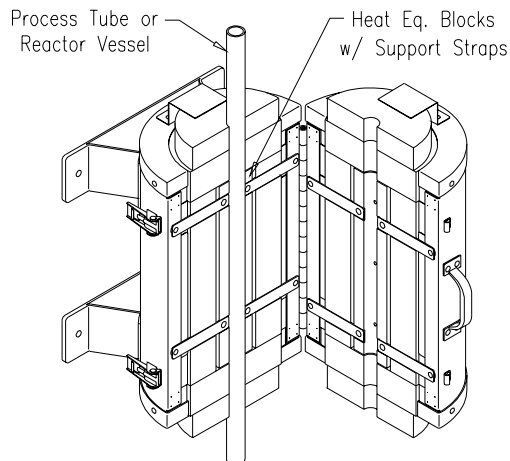

Fig. 1: Heat Equalizing Blocks

• Controlled-Atmosphere Furnaces

Controlled-atmosphere furnaces are designed for performing processes or for heating samples in a specific (typically inert) environment. ATS Series 3150 and 3350 box furnaces serve as the foundations for our controlled-atmosphere furnaces, referred to as Series 3150CA and 3350CA furnaces, for operating temperatures up to 3100°F (1700°C). (*Maximum temperature is based on an argon, helium, or nitrogen environment. Other atmospheres may further reduce the allowable temperature.*)

Standard construction features include a heavy-gage stainless steel shell, low K-factor vacuum-cast ceramic fiber insulation, a full-opening front door, gas inlet and venting ports, a pressure regulator, and a safety relief valve. Optional features include stainless steel bellows assemblies for use with testing fixtures, sealed laser gaging ports, and a vacuum pump for air evacuation. (*Note: These furnaces are NOT designed to create a vacuum environment. The optional vacuum pump is for initial purging of air and maintenance of the furnace atmosphere only.*) See page 31 of this bulletin for an example photograph.

Accessories

Sealed Retort Assemblies

While controlled-atmosphere furnaces are useful in a number of laboratory and industrial situations, a more economical way to carry out high-temperature controlled-environment testing, including operation in a vacuum, is with an ATS Series 3910 or 3920 retort assembly. Available with a wide variety of options and accessories, ATS retort assemblies offer years of dependable service and are built-to-order to your specifications.

Series 3910 retort assemblies are constructed from high-temperature metals, typically stainless steel or Inconel, and utilize integral welded-flange construction, meaning that end flanges are not interchangeable. If more versatility is desired, Series 3920 retort assemblies feature replaceable end flanges, making it possible to easily attach various accessories or other fittings to suit any test. Series 3920 retorts are available in metal (including stainless steel and Inconel), ceramic (alumina or mullite), and quartz.

Retorts may be open on one or both ends and are capable of holding a vacuum as low as 10^{-6} torr under appropriate conditions. Maximum internal pressure is 2 psi (14 kPa). Common options and accessories include water-cooled pull rods, packing gland and bellows-type seal assemblies, mounting brackets, heat shields to protect end flanges from heat radiation, high-temperature retort extensometers, water-cooling collars, displacement transducers, accessory chambers, relief valves, vacuum valves, gas ports, and more.



Examples of ATS retort assemblies:

(a) Series 3910 Inconel retort, welded type, with packing gland seals and mounting brackets.

(b) Series 3920 Inconel retort, interchangeable type, with accessory cross chamber and flange assemblies for use with test machines.

(c) Series 3920 ceramic retort, special construction, with mounting brackets.

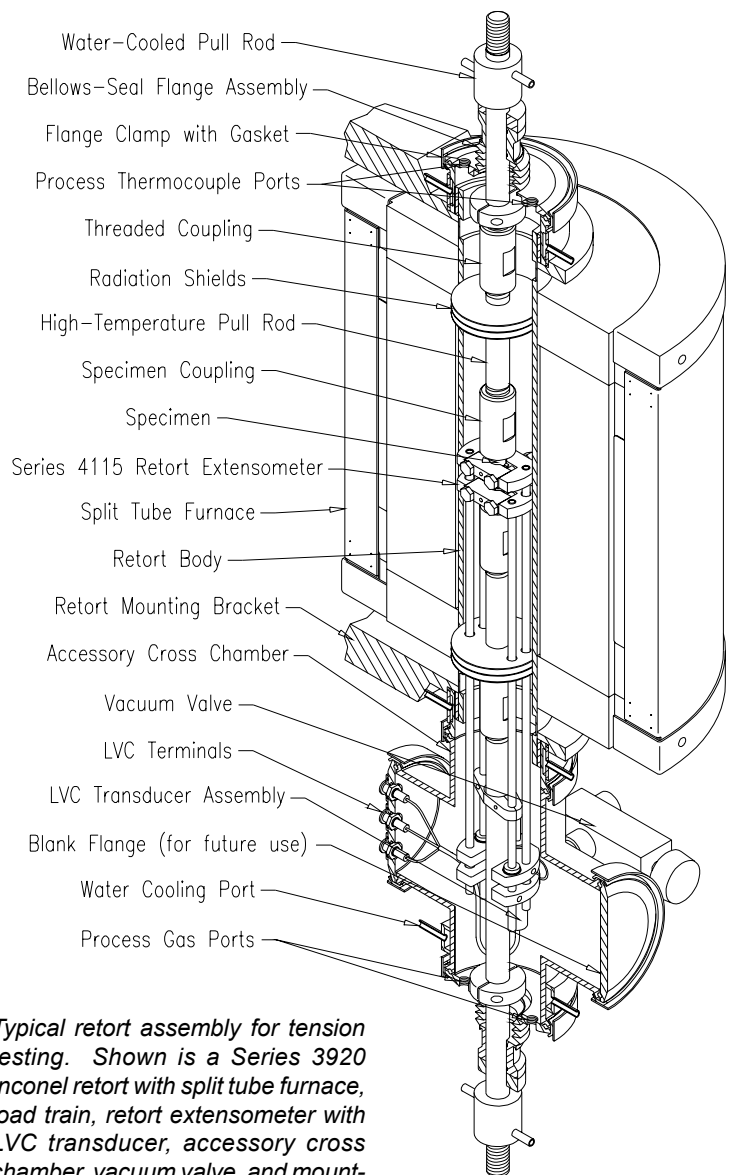

Typical retort assembly for tension testing. Shown is a Series 3920 Inconel retort with split tube furnace, load train, retort extensometer with LVC transducer, accessory cross chamber, vacuum valve, and mounting brackets.

Furnace Mounting Components

With over 30 years of experience in the materials testing field, ATS has developed furnace mounting solutions to fit nearly every type of test frame or support structure imaginable. For everything from simple laboratory baseplates and support brackets to the most complex mounting assembly you can dream up for your application, ATS has the necessary knowledge and expertise to make it work. The following pages detail some of the typical mounting configurations used with ATS furnaces.

Basic Support Brackets

The most common mounting option for ATS tube and split tube furnaces is our standard support bracket for either horizontal or vertical use. Brackets are stainless steel, and sizes are available to fit any standard ATS furnace. Leveling feet are included when furnaces are to be used horizontally. Custom brackets, in varying sizes or with different mounting holes, are available to suit your application.

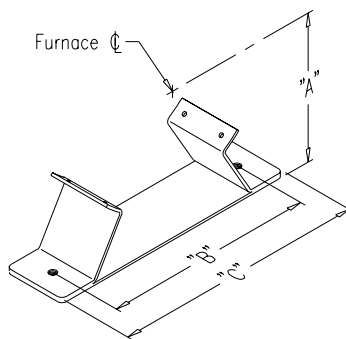

Furnace O.D.	"A"	"B"	"C"
5.0"	4.50"	5.00"	7.00"
6.0"	5.00"	6.00"	8.00"
8.0"	6.00"	8.00"	10.0"
10.0"	7.00"	10.0"	12.0"
12.0"	8.00"	14.0"	16.0"
14.0"	9.00"	16.0"	18.0"
16.0"	10.0"	18.0"	20.0"
18.0"	11.0"	20.0"	22.0"
20.0"	12.0"	22.0"	24.0"
22.0"	13.0"	24.0"	26.0"
24.0"	14.0"	26.0"	28.0"

Fig. 1: Support Brackets
Bracket width is determined at time of order. Mounting holes are 3/8"-16UNC-2B.

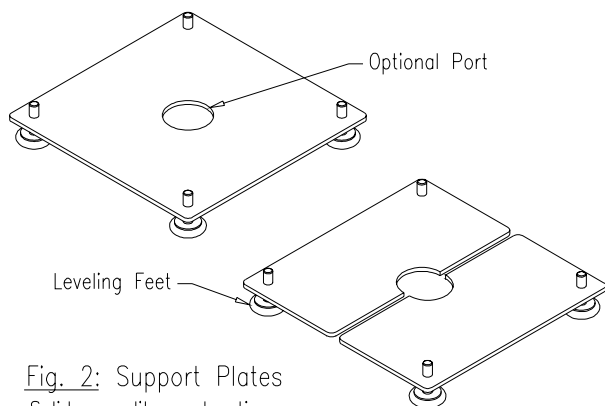

Fig. 2: Support Plates
Solid or split construction.

Laboratory Support Plates

These black painted steel support plates are an economical mounting option suitable for many laboratory applications. Tube or split tube furnaces simply rest on top, secured by screws. Support plates are sized to match the outside diameter of the furnace, and leveling feet are included. Optional ports can be installed to allow process tubing, reactor vessels, or load train components to pass through the furnace.

Tube Furnace Mounting Brackets

Tube furnace mounting brackets serve as the basic component in many ATS mounting assemblies. Brackets are designed to fit standard ATS furnace bars, which are 1.18" (30mm) in diameter. Brackets are black painted steel and are available to suit either tube or split tube furnaces. Custom mounting brackets for any size of furnace or furnace bar are available.

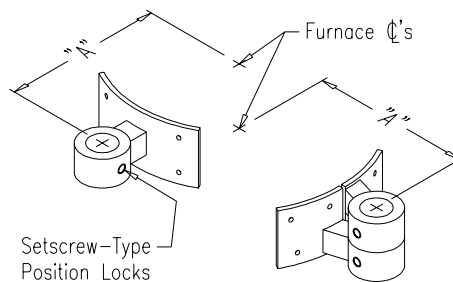

Furnace O.D.	"A"
6.0"	5.88"
8.0"	6.88"
10.0"	6.88"
12.0"	8.75"
14.0"	8.75"
16.0"	10.75"
18.0"	10.75"
20.0"	12.75"
22.0"	12.75"
24.0"	14.75"

Fig. 3: Mounting Brackets
Solid or split construction; also available for box and split box furnaces. Bracket height is determined at the time of order.

Mounting

Laboratory Baseplates

ATS laboratory baseplates provide a vertical mounting system with much more versatility than the simple laboratory support plates detailed on the previous page. Baseplates are black painted steel and are supplied with a standard ATS furnace bar (1.18" [30mm] diameter). Furnace bars are available from stock in a variety of standard lengths. Baseplates are free-standing and are suitable for either benchtop or floor operation. Optional ports can be installed to suit your application. Baseplates are available in either standard or heavy-duty models, and exact dimensions are determined at the time of order.

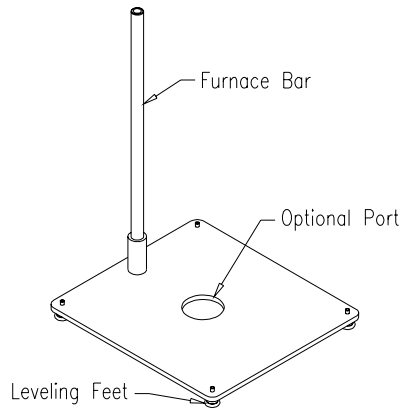

Fig. 1: Laboratory Baseplate Standard-duty model. Baseplate size is determined at time of order.

Standard furnace bars are 1.18" (30mm) diameter. Bars are available from stock in lengths of 10", 12", 14", 16", 18", 20", 22", 24", 26", 28", 30", and 36". Custom lengths and diameters are available.

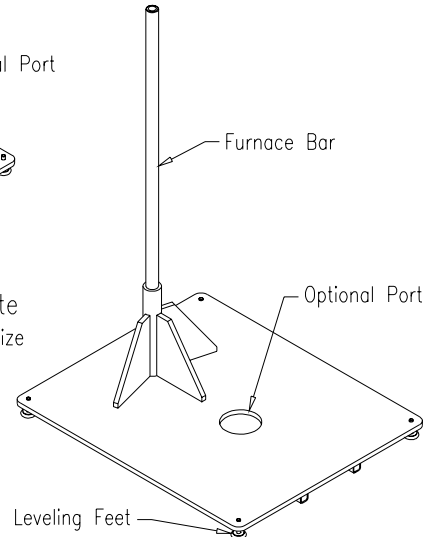

Fig. 2: Laboratory Baseplate Heavy-duty model. Baseplate size is determined at time of order.

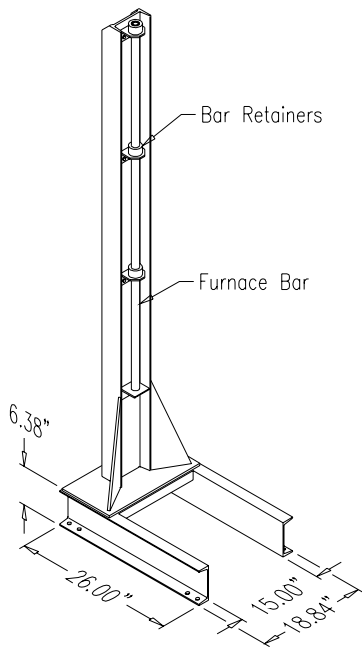

Fig. 3: Vertical Support Stand Standard-duty model. Sizes are as shown. Height is determined at time of order. (Frame must be anchored to floor. Holes in base are 9/16" diameter)

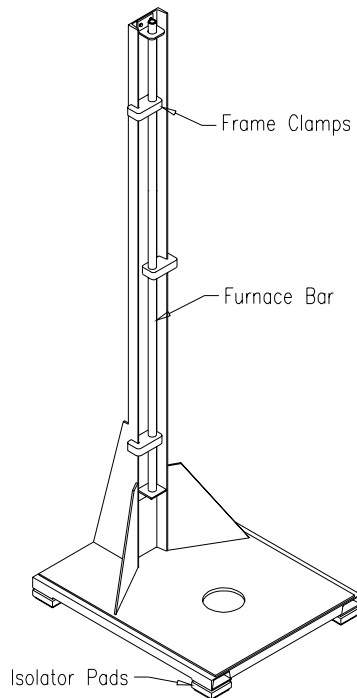

Fig. 4: Vertical Support Stand Heavy-duty model. Configuration and sizes are determined at time of order.

Vertical Support Stands

For supporting larger furnaces in the laboratory and in various industrial applications, ATS vertical support stands offer a rugged and versatile mounting option. Support stand frames are constructed from steel plates and structural beams with a black painted finish, and they are supplied with either a standard ATS furnace bar or a larger-diameter bar, depending upon the furnace size and the specific application. Two basic stand types are available, including an economical structural frame, which must be securely anchored to the floor, and a heavy-duty free-standing frame. Vertical support stands are capable of holding multiple furnaces along with various reactors, vessels, and other fixtures.

Test Frame Mounting Assemblies

ATS offers a number of standard test frame mounting assemblies, as shown on the following pages. Mounting assemblies are suitable for use with tube, split tube, and split box furnaces and can be reversed for either left-hand or right-hand operation. The accompanying diagrams demonstrate two-column test machines, but each assembly can easily be adapted to fit four, six, or any number of test frame support beams or columns. As always, custom mounting inquiries are welcome.

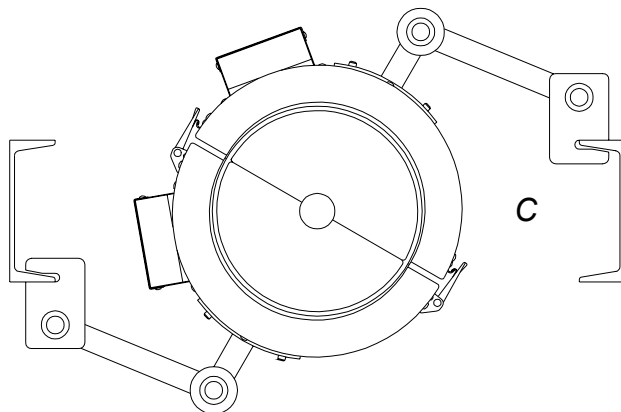
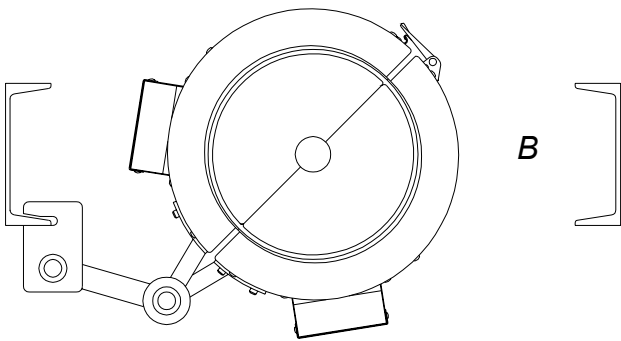
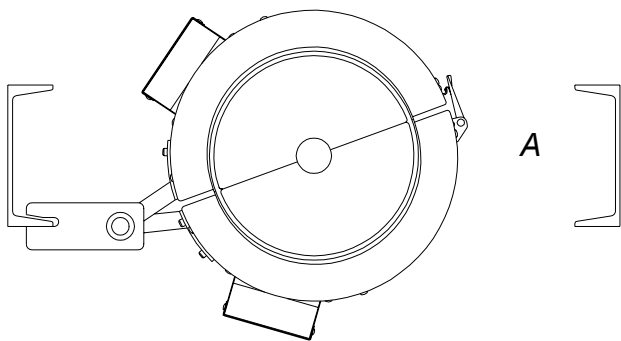
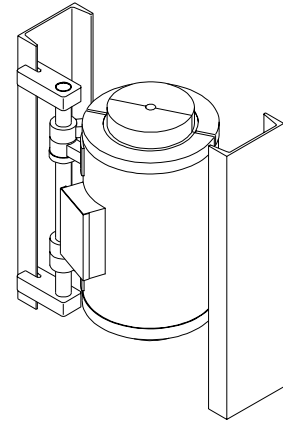

Structural Frames

Many systems, including creep testing frames, industrial support structures, and “homemade” laboratory test frames, use structural steel beams in their design. ATS produces a wide array of structural frame clamps, furnace bar brackets, and mounting brackets to fit such configurations. These components form the basis for mounting assemblies A, B, and C, shown at left.

A) Single Pivot Mounting Assembly: This is the simplest and least expensive option for vertical mounting of a furnace on a structural frame.

B) Double Pivot Mounting Assembly: Offering more versatility than a single pivot mounting assembly, this option allows some adjustment in the location of the furnace centerline, and it allows the furnace to easily swing out of the way when not in use.

C) Dual Double Pivot Mounting Assembly: With both furnace halves able to move freely, this mounting assembly offers maximum versatility in setting up load train components and tests. This configuration is also sometimes the only suitable option in restricted-space situations.

Mounting

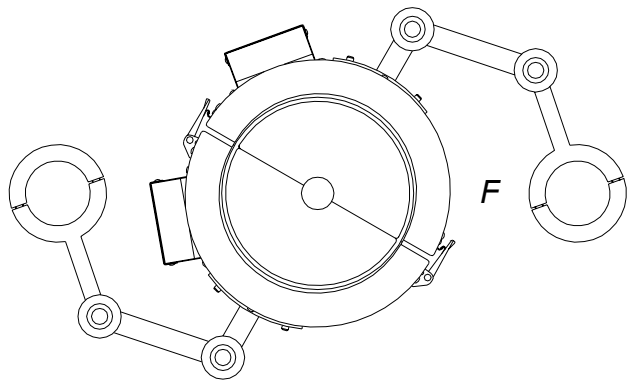
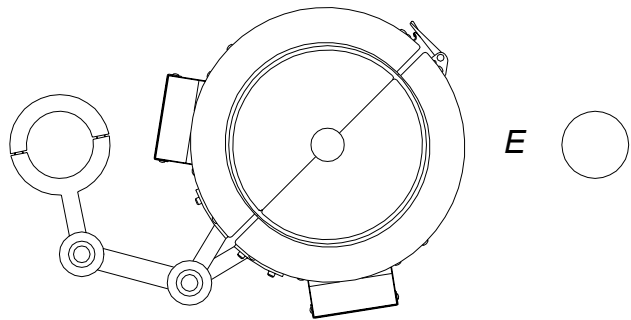
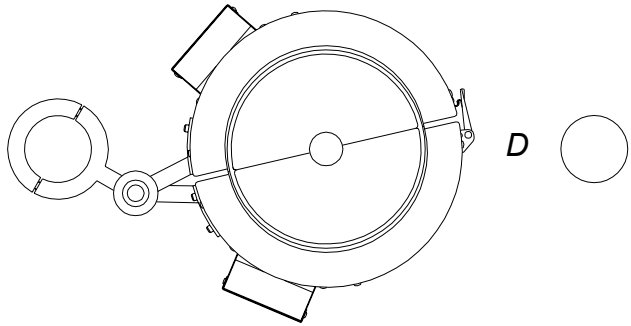

UTM Baseplate

Many universal testing machines do not provide a suitable means of mounting a furnace. In such cases, a miniature baseplate with furnace bar can be mounted to the lower cross-head of the machine, as shown in figure G.

G) UTM Baseplate Mounting Assembly: Shown is a single pivot mounting assembly with a baseplate bracket. Any of the mounting assemblies on this page can be accommodated in this way.

Vertical Support Columns

Universal testing machines, fatigue testers, and other systems often feature vertical columns in their design. ATS produces mounting assemblies for these machines which are similar to the structural frame mounting options on the preceding page. Vertical-column mounting assemblies are shown at left in figures D, E, and F.

D) Single Pivot Mounting Assembly: Similar to figure A on the previous page.

E) Double Pivot Mounting Assembly: Similar to figure B on the previous page.

F) Dual Double Pivot Mounting Assembly: Similar to figure C on the previous page.

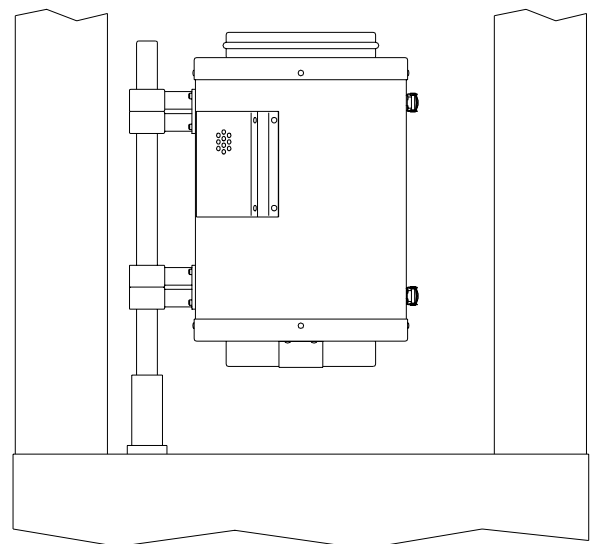
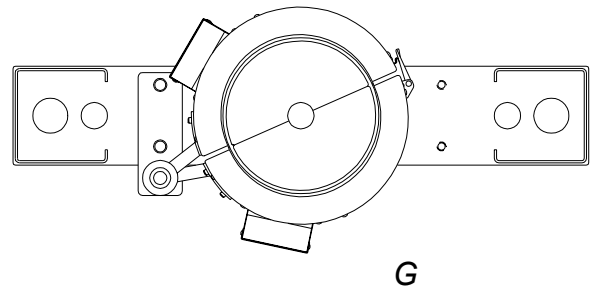

Custom Equipment

Custom Furnaces

Since 1965, ATS has proven itself as an expert supplier of custom testing equipment, and our line of furnaces is no exception. On the following pages, you will find examples of some of the hundreds of custom furnaces, complete process systems, and unique mounting assemblies that ATS has successfully delivered over the years, perfectly meeting our customers' needs and expectations. Contact an ATS sales engineer today to discuss how we can create an ideal, custom-engineered solution to suit your specific test, procedure, or application.



Series 3210 Split Tube Furnace: Constructed with extensometer flat and access slot. Includes lower end cap with retainers.



Series 3110 Tube Furnace: Narrow furnace with extra-thin end disks, special thermocouple configuration, and custom support brackets.



Series 3210 Split Tube Furnace: Featuring split-line access ports and side heating chamber to fit customer's reactor vessel.



Series 3110 Tube Furnace: With custom cast-bronze heating element, purging and cooling ports (in rear), lifting ports, and removable front cover (not shown).



Series 3210 Split Tube Furnace: Shown with AMPCO-18 heat-equalizing blocks. Blocks include internal air cooling ports.

Custom Equipment



Series 3150CA Controlled-Atmosphere Box Furnace: Featuring water-cooled silicone rubber door gasket, cooling water manifold with control valves and flow sensor, gas ports, thermocouple ports, and vacuum pump, pressure regulator, and relief valve (not shown).
See page 24 of this bulletin for more information.



Series 3420 Multi-Zone Split Tube Furnace: Two-zone construction with standard laboratory baseplate and vertical furnace bar.



Special Series 3150 Box Furnace: Special construction with top lid assembly (not shown) and solid copper heat-equalizing block configured for simultaneous heating of 20 test tubes.

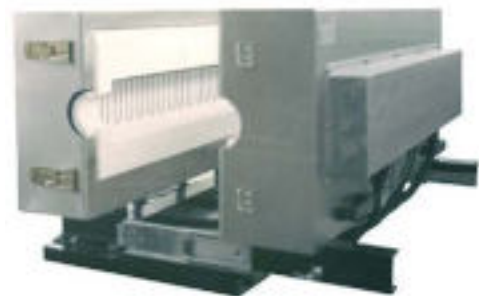

Series 3360 Horizontal Split Tube Furnace: Multi-zone high-temperature tube furnace mounted on custom sliding-rail baseplate.



Series 3410 Multi-Zone Tube Furnace: Designed for continuous heat treatment of multiple strands of wire. Furnace featured 6 independently-controlled heat zones, each 24" (0.6m) long, for a total heated length of 144" (3.6m). Included a structural steel support frame.



Special Series 3210 Split Tube Furnace Assembly: Constructed with six vertical heating chambers inside a single furnace shell for reduced manufacturing costs.

Custom Equipment

Custom High-Temperature Process Systems

In addition to supplying furnaces for use in high-temperature testing and production, ATS has extensive experience in providing complete, custom-designed process systems for use in these applications. Our talented and creative systems engineers have decades of combined experience in mechanical design, pneumatics, hydraulics, electronics, and a variety of other of fields. Below are some examples of past furnace systems produced by ATS. Consult an ATS sales engineer to discuss any application or setup you may have in mind.



Dual-Station Computer-Controlled Carbon Reactivity Test System: Including split tube furnaces, reactor vessels, pneumatic lift system for specimen loading, and integrated temperature and gas flow control systems.

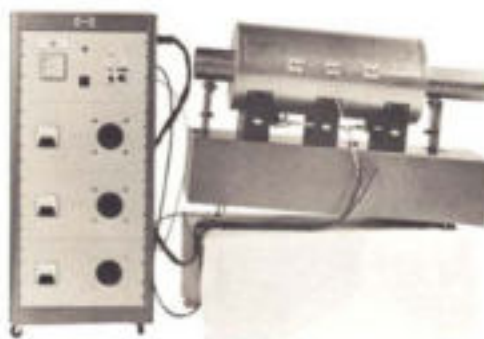

Reduction Tube Drive System: Featuring three-zone furnace, reduction tube, rotary drive system, and control cabinet.



Tube Furnace Rocking Mechanism: Designed to continuously agitate material inside of a furnace tube through an arc of 22.5° at a rate of up to 15 cycles per minute.



High-Temperature Rotary Calciner: Complete system including three-zone furnace, support frame with mechanical pitch adjustment, stainless steel hopper with vibratory feeder, rotary tube with agitator and speed control, and integrated control system for all components.

Custom Equipment

Custom Mounting Arrangements

As mentioned previously, ATS has over 30 years of experience in the high-temperature testing field and has the capability to develop and deliver furnace mounting solutions to fit an endless variety of test frames and support structures. Below are some of the mounting systems that ATS has designed in the past. Contact an ATS sales engineer to discuss a suitable mounting system for your laboratory or industrial application.



Tandem Vertical Support Stand: Heavy-duty furnace stand for mounting of two furnaces and accessories. Special blue painted finish.



Vertical Support Stand with Rails: The sliding rail system on this structural support frame allowed each furnace half to move out of the way for unrestricted access to a vessel hanging inside the furnace.



Adjustable Furnace Tilt Stand: Table-top frame for mounting of two tube furnaces with a ceramic tube running lengthwise and a hand crank for manual adjustment of the pitch angle.



Specimen Loading Systems: Shown is a manual rack-and-pinion system (left) for raising and lowering a furnace onto a specimen and a motorized lift (right) for loading and unloading of specimens into a furnace.

Custom Equipment

Custom Industrial Furnaces

The experienced designers at ATS partner with the talented furnace construction team of ATS's main subsidiary, Electro Heat Systems (EHS), which manufactures all of the heating elements used in ATS Series 3110, 3210, 3150, and 3160 furnaces, to produce durable, custom industrial furnaces for use in drying, curing, annealing, stress-relieving, burn-off, purification, heat treating, and a variety of other applications. Below are some recent examples of ATS/EHS industrial furnace systems. Contact an ATS sales engineer to discuss your unique industrial furnace needs.



Cell Furnace: Large split furnace designed for heating vats of liquid. Chamber is 89" (2.26m) inside diameter by 82" (2.08m) high. Operating temperature is 1800°F (980°C). Furnace is supported on a sliding rail system for easy loading and unloading.



Box Furnace: For annealing, hardening, tempering, and general heat treating. Chamber is 30" (0.76m) wide by 30" (0.76m) high by 48" (1.21m) deep. Operating temperature is 2200°F (1200°C). Furnace featured air-assisted vertical lift door.



Ethylene Cracking Furnace: This furnace was designed as part of a petrochemicals pilot plant. Chamber is 78" (1.98m) wide by 60" (1.52m) high by 10" (0.25m) deep. Operating temperature is 2200°F (1200°C). Furnace features pneumatic sliding door.



Twin-Parallel Tube Furnace: Used in an electronics plant. Furnace featured two heating chambers, each 6" (0.15m) inside diameter by 54" (1.37m) long. Operating temperature is 2200°F (1200°C). Includes internal support blocks for quartz tubes.

Temperature Control Systems

It is obvious that a furnace can only be as precise as its control system. Since the beginning, therefore, ATS has placed great emphasis on providing complete, accurate temperature control systems using only the highest-quality components. ATS currently specializes in control systems using the three units shown below, which have been selected for their accuracy, versatility, and reliability. Custom control systems are also available using any major-brand temperature controller, including Honeywell, Watlow, Athena, LFE, and others. Consult an ATS sales engineer to discuss your ideal temperature control system.

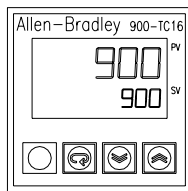

• Allen-Bradley® Series 900-TC16 Digital Setpoint Controller

Reliable, low-cost setpoint controller featuring compact construction, alarm and control outputs, heater burnout detection, optional digital communications, selectable units ($^{\circ}\text{F}$ or $^{\circ}\text{C}$), a variety of temperature sensor inputs, three security levels, and optional 900Builder™ PC software for computerized configuration. *This controller can also function separately as a high-limit alarm unit.*



• Barber-Colman® Series 2404 Programmable Controller

Advanced programmable temperature controller ideal for single and multi-zone furnaces, featuring high-stability control, 4 programs with 16 ramp/dwell segments each, heating and cooling functionality, customized operation, load diagnostics, heater current display, multiple alarm outputs, and digital communications. *Often used in conjunction with Series 2204 High-Limit Alarm Unit.*

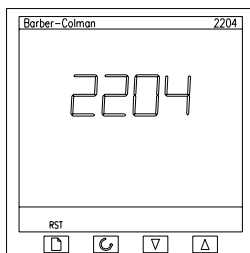
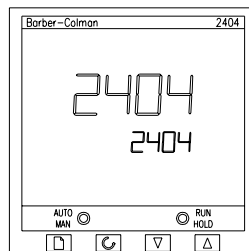

• Barber-Colman® Series 2204 High-Limit Alarm Unit:

Reliable high-limit controller to protect furnaces from over-temperature conditions, featuring universal input circuit with advanced A/D converter for high stability and rapid response, high noise immunity, a wide range of temperature sensor inputs, independent alarm outputs, user-defined operator interface, and password protection for system security.



• Complete Temperature Control Systems:

Shown above are examples of complete single and multi-zone furnace temperature control systems. Available features include cabinets with rack-mount panels, transformers, SCR units, gas/cooling supply systems, and other options. Whatever your specific application may be, ATS has the knowledge and experience to build a control system to suit all of your needs.



Certification
Program Now
Available

ATS APPLIED TEST
SYSTEMS, INC.

*154 East Brook Lane
Butler, PA 16002*

Phone: (724) 283-1212
Toll-Free: (800) 441-0215
Fax: (724) 283-6570
eMail: sales@atspa.com
<http://www.atspa.com>

Kanthal Super® is a
registered trademark of
the Kanthal Corporation

